



**Compact Series  
Instruction Manual**

**Serie compacta  
Manual de instrucciones**

**Série Compact  
Manuel d'instructions**

**Kompaktwaagen-Serie  
Bedienungsanleitung**

**Serie compatta  
Manuale di istruzioni**

**コンパクト シリーズ  
使用説明書**

**小型 系列  
使用手冊**

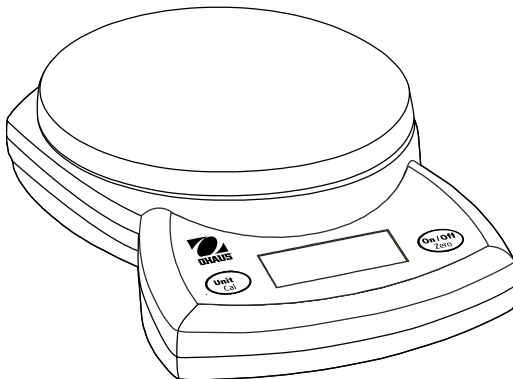

# 1. INTRODUCTION

This manual contains installation and operation instructions for the Compact Series Scales. Please read the manual completely before using the scale.

## 1.1 Safety Precautions

Please follow these safety precautions:

- Verify that the AC Adapter input voltage matches the local AC power supply.
- Use the scale only in dry locations.
- For best results, use the scale in the specified optimum operating temperature.
- Do not operate the scale in hostile or unstable environments.
- Use your scale with care, gently loading items to be weighed onto the center of the pan. Avoiding rough treatment will aid in the life of your scale.

## 1.2. General Product Features

- **Power Up test:** When the scale is turned on, all display segments will be displayed for a few seconds, indicating that the unit is self adjusting to zero. Once the "0" is displayed, the scale is ready for use.
- **Stable Reading indication:** A star indicator will appear in the lower left corner of the display when a stable reading has been reached.
- **Overload:** If the applied load exceeds the capacity of the scale, an "E" will appear on the display and the load should be removed immediately. The scale will return to normal operation.
- **Tare Function:** Values can progressively be added to a sample. By pressing the **On/Off Zero** button, the scale display returns to zero. After adding additional mass, press **On/Off Zero** to zero the scale again. Additional mass may be added up to the capacity of the scale.
- **Negative Value:** When a load is removed from the scale, any zeroed value will be displayed as a negative number. To return to normal operation, the zeroed value can be cancelled by pressing **On/Off Zero** button.
- **Low Battery Indication:** The display will show "Lo" when the batteries are weak and need to be replaced.

- **Auto Shut-Off:** To extend battery life, the scale will automatically turn off after approximately (4) minutes if no active weighing is occurring. This feature is active with battery operation only.

## 2. INSTALLATION

### 2.1 Power

Power the scale using the AC power adapter (not included with CSxxxE) or 3 AA batteries.

#### Battery Installation

Remove the battery cover on the bottom of the scale and place the 3 "AA" size batteries into the compartment as indicated.

Do not use excessive force or press on the weighing pan.

Re insert the battery cover.

#### AC Power Connection

Connect the AC adapter (not included with CSxxxE) to the receptacle at the rear of the scale.

Plug the AC adapter into a properly grounded electrical outlet.

### 2.2 Stainless Steel pan (provided with some models)

Place the stainless steel pan (if provided) onto the weighing platform before turning the scale on. The scale can be operated without the pan, if desired.

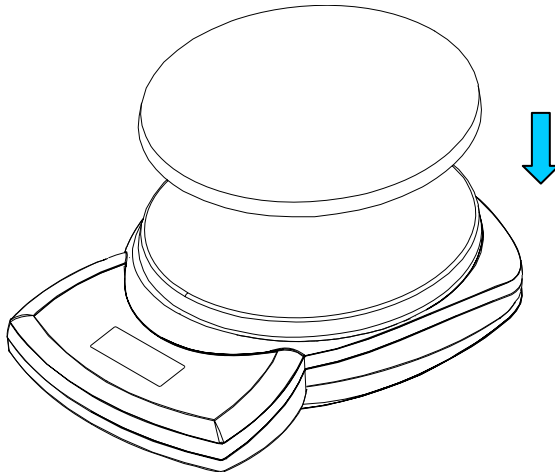

## 3. OPERATION

### 3.1 Two Button Keypad

- **On/Off Zero:** Pressing this button turns on the scale. This same button operates the zero feature when the scale is on. Press and hold this button for three seconds to turn the scale off.
- **Unit Cal:** Press this button briefly to change the weighing unit. Press and hold this button to begin the calibration process.

### 3.2 Calibration

For best results calibrate the scale at regular intervals. This is especially important if the scale is in use for prolonged periods.

Calibration weights are not provided with the scale

- Press and hold the **Unit Cal** button to start the calibration process. The display will show CAL.
- The calibration process can be aborted by turning the scale off.
- Press the **On/Off Zero** button to capture 0. The display shows –C– while the scale stores the zero load signal.
- The display will show C xxx where xxx is the calibration weight in grams.
- Place the appropriate calibration weight on the platform.
- Press the **On/Off Zero** button.
- The display shows –C– while the scale stores the calibration point signal.
- After calibration, the display returns to the normal weighing mode.

The message CAL E will appear if the calibration steps are not followed or the wrong weight was used.

## 4. ACCESSORIES

AC Power adapter:	Ohaus Part No.
Universal Adapter	46001724
Universal Plugs kit (4)	46001780
Calibration Masses:	
200g (for 200,300 models)	51025-25
1000g (for 2000 model)	51025-16
2000g (for 2500, 5000 models)	51025-26
1050 ml Bowl	80850075
Stainless steel pan	80850076
Carrying Case	80010624

## 5. SERVICE INFORMATION

For service assistance or technical support in the United States call toll-free 1-800-526-0659 between 8:00 AM and 5:00 PM EST. An Ohaus product service specialist will be available to provide assistance. Outside the USA, please visit our web site, [www.ohaus.com](http://www.ohaus.com) to locate the Ohaus Office nearest you.

## 6. TECHNICAL DATA



### 6.1 Specifications

**TABLE 6-1. SPECIFICATIONS.**

Model	200	300	2000	2500	5000
Capacity (g)	200	300	2000	2500	5000
Readability (g)	0.1	0.1	1	1	1
Repeatability (g)	0.1	0.1	1	1	1
Linearity (g) (+/-)	0.1	0.1	1	1	1
Weighing Units	CS	grams, ounces, pound:ounces, Newtons			
	JR	grams, pound:ounces, troy ounces, pennyweights			
	JRxxxT	grams, Hong Kong tael, Singapore tael, Taiwan tael			
Tare Range	To capacity by subtraction				
Stabilization Time	≤ 3 seconds				
Power Requirements	AC Adapter (not included with CSxxxE) or 3-AA (LR6) alkaline batteries				
Calibration	Digital with external weight				
Optimum Operating Temperature	64° to 77°F / 18° to 25°C				
Typical Battery Life	300 hours				
Overall Size (mm/in)	205 x 140 x 40 / 8.00 x 5.50 x 1.58				
Pan Size (mm / in)	145 x 133 / 5.75 x 5.25				
Net Weight (kg / lb)	0.4 / 0.9				
Shipping Weight (kg / lb)	1.0 / 2.0				

**6.2 Compliance**

Compliance to the following standards is indicated by the corresponding mark on the product.

Mark	Standard
	This product conforms to the EMC directive 2004/108/EC and the Low Voltage Directive 2006/95/EC. The complete declaration of Conformity is available from Ohaus Corporation.
	AS/NZS4251.1, AS/NZS4252.1

	<p><b>Disposal</b></p> <p>In conformance with the European Directive 2002/96 EC on Waste Electrical and Electronic Equipment (WEEE) this device may not be disposed of in domestic waste. This also applies to countries outside the EU, per their specific requirements.</p> <p>Please dispose of this product in accordance with local regulations at the collecting point specified for electrical and electronic equipment. If you have any questions, please contact the responsible authority or the distributor from which you purchased this device.</p> <p>Should this device be passed on to other parties (for private or professional use), the content of this regulation must also be related. Thank you for your contribution to environmental protection.</p> <p>For disposal instructions in Europe, refer to <a href="http://www.ohaus.com/weee">www.ohaus.com/weee</a>.</p>
---	--

**FCC Note**

This equipment has been tested and found to comply with the limits for a Class B digital device, pursuant to Part 15 of the FCC Rules. These limits are designed to provide reasonable protection against harmful interference in a residential installation. This equipment generates, uses and can radiate radio frequency energy and, if not installed and used in accordance with the instructions, may cause harmful interference to radio communications. However, there is no guarantee that interference will not occur in a particular installation. If this equipment does cause harmful interference to radio or television reception, which can be determined by turning the equipment off and on, the user is encouraged to try to correct the interference by one or more of the following measures:

- Reorient or relocate the receiving antenna.

- Increase the separation between the equipment and receiver.
- Connect the equipment into an outlet on a circuit different from that to which the receiver is connected.
- Consult the dealer or an experienced radio/TV technician for help.

**Industry Canada Note**

This Class B digital apparatus complies with Canadian ICES-003.

**ISO 9001 Registration**

In 1994, Ohaus Corporation, USA, was awarded a certificate of registration to ISO 9001 by Bureau Veritas Quality International (BVQI), confirming that the Ohaus quality management system is compliant with the ISO 9001 standard's requirements. On May 15, 2003, Ohaus Corporation, USA, was re-registered to the ISO 9001:2000 standard.

**LIMITED WARRANTY**

Ohaus products are warranted against defects in materials and workmanship from the date of delivery through the duration of the warranty period. During the warranty period Ohaus will repair, or, at its option, replace any component(s) that proves to be defective at no charge, provided that the product is returned, freight prepaid, to Ohaus. This warranty does not apply if the product has been damaged by accident or misuse, exposed to radioactive or corrosive materials, has foreign material penetrating to the inside of the product, or as a result of service or modification by other than Ohaus. In lieu of a properly returned warranty registration card, the warranty period shall begin on the date of shipment to the authorized dealer. No other express or implied warranty is given by Ohaus Corporation. Ohaus Corporation shall not be liable for any consequential damages.

As warranty legislation differs from state to state and country to country, please contact Ohaus or your local Ohaus dealer for further details.

Register your scale under *Warranty Registration* at [www.ohaus.com](http://www.ohaus.com)