

8200 Series Hanging Scales - 13-inch Dial

The CHATILLON® 8200 Series hanging scale are crafted of chrome-plated steel with machines stainless steel pinions and a phosphor bronze rack combination for virtually frictionless performance. The 13-inch double dial reaches full capacity in three revolutions. Runners are indexed for each revolution. Brass air dashpots eliminate pointer oscillation.

The 8200 Series may be specified as a Class III "Legal for Trade" scale. Available in avoirdupois and metric models, the 8200 Series can be supplied with a bottom hook (nickel plated steel) or the popular AS circular pan. The AS Pan is constructed of stainless steel. The supporting ring and bow are of nickel plated steel. The removable 5-inch deep round pan has drain holes and is USDA approved for use in general food handling.

Features

- ❑ Avoirdupois and Metric Graduations
- ❑ Available as H44 Class III "Legal for Trade"
- ❑ Full Capacity in Three Pointer Revolutions
- ❑ Double 13-inch Dials (Glass Covered)
- ❑ Bottom Hook or AS Pan Attachments
- ❑ 1 Year Warranty

Specifications

- Accuracy:** (See Tables Below)
Maximum Overload: 120% of Rated Capacity
Tare Capacity: 10% Full Scale Capacity
Weight with Hook: 14 lbs (7 kg)
Weight with AS Pan: 18 lbs (9 kg)



Shown with bottom hook



Shown with optional AS Pan

Certificate of Conformance No. 88-060, Model 0028/A was issued under the national Type Evaluation Program of the National Conference on Weights and Measures, that the design conforms to NIST Handbook 44 Class III. The scale is "Legal for Trade" subject to on-site verification by the local Weights and Measures jurisdictions.

Accuracies - Class III

Model	Resolution	Range	Scale		Tolerance		
			Divisions	Division	Weight	%Accurate	
8230DD-S	30 lb x 1 oz	0-3 lb	0-50	+1/2 d	+0.5 oz	+0.10%	
			51-200	+1 d	+1 oz	+0.21%	
			201-400	+1-1/2 d	+1.5 oz	+0.31%	
			401 +	+2-1/2 d	+2.5 oz	+0.52%	
8260DD-S	60 lb x 2 oz	0-3 lb	0-50	+1/2 d	+0.5 oz	+0.05%	
			51-200	+1 d	+1 oz	+0.10%	
			201-400	+1-1/2 d	+1.5 oz	+0.16%	
			401 +	+2-1/2 d	+2.5 oz	+0.26%	
K8215DD-S	15 kg x 50 g	0-1 kg	0-50	+1/2 d	+10 g	+0.07%	
			51-200	+1 d	+20 g	+0.13%	
			201-400	+1-1/2 d	+30 g	+0.20%	
			400 +	+2-1/2 d	+50 g	+0.33%	
K8230DD-S	30 kg x 50 g	0-2 kg	0-50	+1/2 d	+25 g	+0.08%	
			51-200	+1 d	+50 g	+0.17%	
			201-400	+1-1/2 d	+75 g	+0.25%	
			400 +	+2-1/2 d	+120 g	+0.42%	

Accuracies - Class III "Legal for Trade"

Model	Resolution	Range	Scale		Tolerance		
			Divisions	Division	Weight	%Accurate	
8230DD-T	30 lb x 1/2 oz	0-15 lb	0-500	+1/2 d	+0.25 oz	+0.05%	
			501-2000	+1 d	+0.5 oz	+0.05%	
8260DD-T	60 lb x 1 oz	0-31 lb	0-500	+1/2 d	+0.5 oz	+0.05%	
			501-2000	+1 d	+1 oz	+0.10%	
K8215DD-T	15 kg x 20 g	0-10 kg	0-500	+1/2 d	+10 g	+0.07%	
			501-2000	+1 d	+20 g	+0.13%	

These accuracies and tolerances are based on Handbook 44 Guidelines.

Visit Us on the Web at www.chatillon.com



A registered trademark of AMETEK Inc.

Dimensions

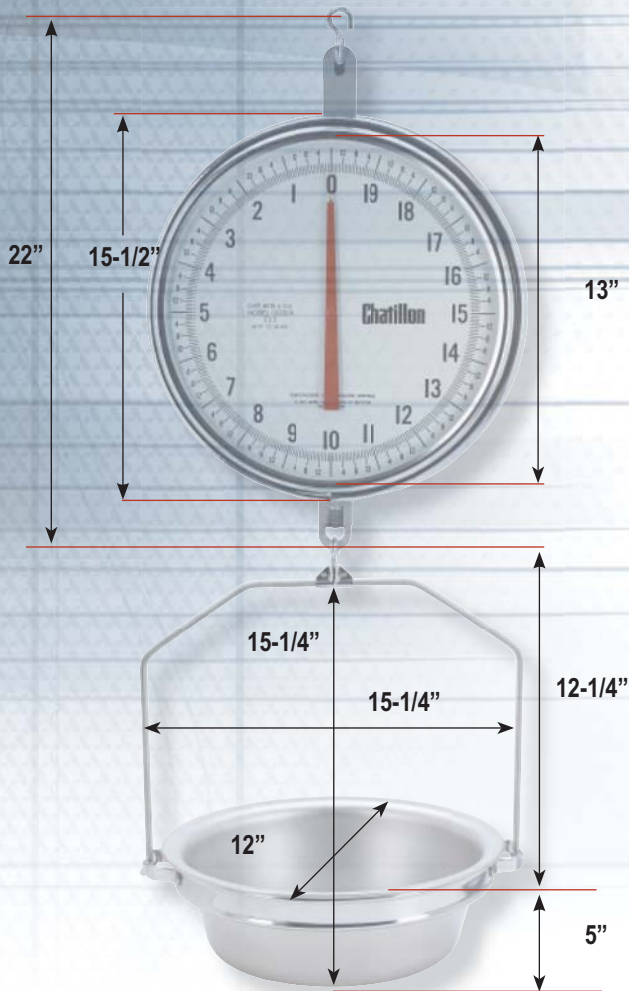

Accessories

Part No.	Description
5854	Bottom Hook
SPK-SCALE-AS	AS Pan Assembly (4 lbs)
7436-1	AS Pan Only
16097	Bow, for AS Pan
16098	Ring, for AS Pan



Ordering

H44 Class III "Legal for Trade"

Old Model	New Model	Capacity	Dial	Attachment
0628HDD	8230DD-T-H	30 lb x 1/2 oz	Double	Bottom Hook
5628ASDD	8230DD-T-AS	30 lb x 1/2 oz	Double	AS Pan
0728HDD	8260DD-T-H	60 lb x 1 oz	Double	Bottom Hook
5728ASDD	8260DD-T-AS	60 lb x 1 oz	Double	AS Pan
K0628HDD	K8215DD-T-H	15 kg x 20 g	Double	Bottom Hook
K5628ASDD	K8215DD-T-AS	15 kg x 20 g	Double	AS Pan

Certificate of Conformance No. 88-060, Model 0028/A was issued under the national Type Evaluation Program of the National Conference on Weights and Measures, that the design conforms to NIST Handbook 44 Class III. The scale is "Legal for Trade" subject to on-site verification by the local Weights and Measures jurisdictions.

H44 Class III "Legal for Trade"

Old Model	New Model	Capacity	Dial	Attachment
8230HDD	8230DD-S-H	30 lb x 1 oz	Double	Bottom Hook
8230ASDD	8230DD-S-AS	30 lb x 1 oz	Double	AS Pan
8260HDD	8260DD-S-H	60 lb x 1 oz	Double	Bottom Hook
8260ASDD	8260DD-S-AS	60 lb x 1 oz	Double	AS Pan
8215KGHDD	K8215DD-S-H	15 kg x 20 g	Double	Bottom Hook
8215KGASDD	K8215DD-S-AS	15 kg x 20 g	Double	AS Pan
8230KGHDD	K8230DD-S-H	30 kg x 50 g	Double	Bottom Hook
8230KGHASDD	K8230DD-S-AS	30 kg x 50 g	Double	AS Pan

AMETEK

US GAUGE DIVISION

Americas
AMETEK US Gauge Division
8600 Somerset Drive
Largo, Florida 33773
United States of America
Tel +1-727-536-7831
Tel +1-800-527-9999
Fax +1-727-539-6882
Email chatillon.fi-har@ametek.com

United Kingdom
Lloyd Instruments Ltd.
12 Barnes Wallis Road
Segensworth East
Fareham
Hants, PO15 5TT
United Kingdom
Tel +44 (0) 1489 486 399
Fax +44 (0) 1489 885 118
Email uk-far.general@ametek.co.uk

France
AMETEK S.A.S.
Rond Point de l'Épine des Champs
Buro Plus - Bat. D
78990 Elancourt
France
Tel +33 (0)1 30 68 89 40
Fax +33 (0)1 30 68 89 49
Email general@lloyd-instruments.com

Germany
AMETEK GmbH
Rudolf-Diesel-Strasse 16
D-40670 Meerbusch
Germany
Tel +49 (0)2159 9136-70
Fax +49 (0)2159 9136-39
Email info@ametek.de

Singapore
AMETEK Singapore Pvt. Ltd.
10 Ang Mo Kio Street 65
#05-12 Techpoint
Singapore 569059
Tel +65-484-2388
Fax +65-481-6588
Email aspl@ametek.com.sg

Visit Us on the Worldwide Web at:
www.chatillon.com

© 2006 by AMETEK, Inc.

Information within this document is subject to change without notice.

ISO 9001/2000
Manufacturer