

GX/GF Series

Electronic Balance

MAINTENANCE MANUAL

GX-200 GX-2000 GX-6000
GX-400 GX-4000 GX-8000
GX-600 GX-6100

GF-200 GF-1200 GF-6000
GF-300 GF-2000
GF-3000

Note This manual is subject to change without notice at any time to improve the product. No part of this manual may be photocopied, reproduced, or translated into another language without the prior written consent of the A&D Company.

Product specifications are subject to change without any obligation on the part of the manufacture.

©2001 A&D Company, Limited

Contents

1. INTRODUCTION	2
1.1 EQUIPMENT AND TOOLS REQUIRED	2
2. PRINCIPLES OF OPERATION	4
2.1 CORRECTIVE MAINTENANCE OUTLINE	5
3. PERFORMANCE TEST	5
3.1 PERFORMANCE TEST PROCEDURE	5
3.2 TEST DETAILS	6
4. CORRECTIVE MAINTENANCE	9
4.1 TROUBLESHOOTING TABLE.....	9
4.2 MAINTENANCE FLOWCHART	14
5. FORCE MOTOR DISASSEMBLY AND REASSEMBLY	15
5.1 DISASSEMBLY.....	16
5.2 CLEANING THE MAGNET ASSEMBLY AND BOBBIN	19
5.3 REASSEMBLY	20
6. ADJUSTMENTS	24
6.1 ADJUSTMENT FLOW CHART.....	24
6.2 GENERAL PRECAUTIONS	25
6.3 CHECK MODE.....	26
6.4 CHECK MODE MENUS.....	27
6.5 INITIALIZATION	28
6.6 MODEL TYPE SELECTION (ONLY FOR MAINTENANCE ELECTRIC BOARD)	29
6.7 COARSE OPERATION CHECK & ADJUSTMENT	30
6.8 COARSE ADJUSTMENT	32
6.9 TEMPERATURE ADJUSTMENT.....	35
6.10 FINE ADJUSTMENT.....	37
6.11 PARAMETER SETTINGS.....	43
6.12 HALF-INITIALIZATION	44
6.13 METHOD OF IDENTIFYING DEFECT LOCATION (ELECTRICAL PART OR MECHANICAL PART)	45

Appendix A: GX Technical Information

Appendix B: GF Technical Information

1. Introduction

For smooth maintenance, the products must be technically understood, and the required equipment and tools must be prepared. Since the GX/GF series electronic balance is a precision instrument, proper operation cannot be guaranteed if the maintenance is performed under unsatisfactory conditions.

GF and GX

Model	Mechanical part		Electric part		
	Internal mass	Drive motor	Clock IC	Backup battery	EEPROM
GX	√	√	√	√	√ (3 ROMs)
GF	-	-	-	-	√ (1 ROM)

1.1 Equipment and Tools Required

Description	Purpose
(1) A phillips screwdriver 3 mm	For disassembling and reassembling
(2) A precision posidrive screwdriver	For securing the motor holder
(3) A precision flat screwdriver	For adjusting the counter weight
(4) An adhesive tape 8 mm	For cleaning the force motor unit
(5) A wrench 5.5 mm	For adjusting the counter weight
(6) An allen wrench 3 mm	For securing the force motor assembly
6 mm	For securing the roberval
1.5 mm	For securing the cam and cam shaft (motor unit)
(7) A drill (shaft only) ϕ 3	For corner load adjustment
(8) A file (round shape)	For corner load adjustment
(9) Round-nose chain pliers	For installing the underhook
(10) Level block	For assembling the force motor unit
(11) A square	For the tension flexure adjustment
(12) A soldering iron (25-40 W)	For soldering wires on force motor
(13) Masses	

F1 class-compliant and cylindrical shape type.

Model	Masses	Model	Masses
GX-200	100g×3, 200g×1	GF-200	100g×3, 200g×1
GX-400	100g×5	GF-300	100g×3, 200g×1
GX-600	100g×2, 200g×3	GF-1200	500g×2, 2kg×2
GX-2000	1kg×3, 2kg×1	GF-2000	1kg×2, 2kg×2
GX-4000	1kg×5	GF-3000	1kg×3, 2kg×1
GX-6100	1kg×1, 2kg×3	GF-6000	2kg×3, 1kg×1
GX-6000	1kg×1, 2kg×3		
GX-8000	1kg×1, 2kg×4		

- (14) Multi-meter (Voltage measurement with 1mV resolution, Resistance measurement for insulation resistance of 20M Ω or more.)
- (15) Oscilloscope
- (16) AC adapter (Use the AC adapter supplied with the balance)
- (17) The balance instruction manual

One set of jig for disassembling or reassembling the force motor (7PA:GX-JIG)

- (1) A board for positioning the beam (GX-1/6)
- (2) A spacer for positioning the roberval (GX-2/6)
- (3) A bolt for holding the beam (GX-3/6)
- (4) Spacers for positioning the beam (2 pcs) (GX-4/6, 5/6)
- (5) A jig for positioning the fulcrum flexure (GX-6/6)
- (6) Pan head screws M4 x 8 (2 pcs), M4 x 12 (2 pcs)

Temperature Controlled Room

A room where the temperature can be maintained at 10 \pm 2°C and 30 \pm 2°C for 8 hours or more.

2. Principles of operation

The GX balances work on the principle of "Force Restoration". Any change in the load on the weighing pan causes a Position Beam Lever to pivot on two Fulcrum Flexures (refer to diagram below). Attached to this beam is a bobbin (wound with fine wire), called the "Force Coil", which floats in a permanent magnet, called the "Force Motor". At the end of the Position Beam Lever there is a small hole which allows light from a Light-Emitting Diode (LED) to pass through to two Photodiodes (light measuring diodes) as it moves up or down. At zero weight, the light detected by the upper Photodiode is equal to that detected by the lower Photodiode. These three diodes make up the Position Detector.

When the Force Coil is pulled up by the leverage exerted from a mass on the weighing pan, the Position Detector detects a change in the position of the Force Coil as the light reaching the upper Photodiode will be greater than that reaching the lower one. The balance then feeds the force coil with more voltage to pull it back until the light measured by the two Photodiodes is equal again. This is accomplished by the Analog Module receiving photocurrent from the Photodiodes, converting it to voltage, and boosting it back to the Force Coil. As the voltage increases, so does the magnetic power, pulling the Force Coil back until the Position Detector reads equilibrium.

The current flowing through the Force Coil generates a voltage proportional to the load weight on the pan. This is read back through the Analog Module, first being filtered - then the Analog-Digital (A/D) Converter digitalizes this measuring voltage, the resulting value is counted and then fed to the microprocessor (CPU).

Temperature affects the magnet and weight data. So temperature coefficient for weight is measured and saved beforehand. The balance eliminates the temperature effect by using the present temperature measured by the temperature sensor and the coefficient. The output from the temperature sensor is converted digitally and sent to the CPU by the analog module.

The CPU performs a mathematical operations in connection with each parameters, such as temperature, linearity coefficient, and calibration data. Also, the user can specify how the calculated information should be displayed by using the keyboard. For example: s/he can have the CPU perform special functions such as conversion into other measuring units, or counting of small parts. Finally, the results are displayed on the Fluorescent Display, or sent through the RS-232C interface.

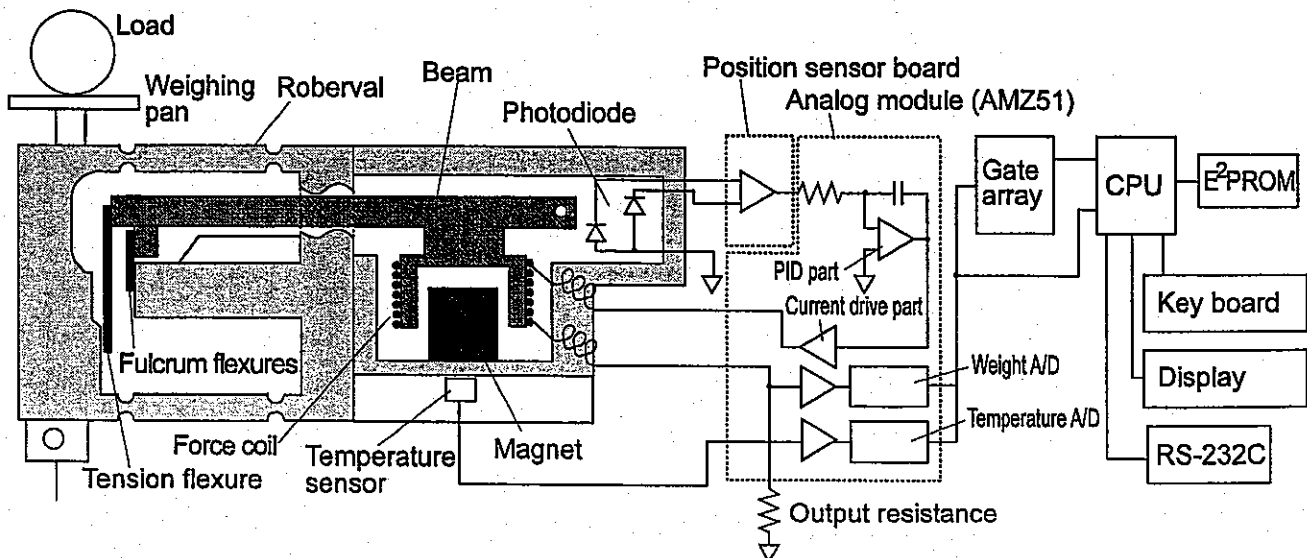

2.1 Corrective Maintenance Outline

Performance test	To perform the corrective maintenance, defects must be located and their cause determined. The easiest way to locate a defect is to perform an operation check.
Corrective maintenance procedure	Corrective maintenance is described by using a flowchart and a trouble-shooting table.
Adjustment details	An adjustment procedure is described for each item.

3. Performance Test

The following test procedures determine whether the balance (GX/GF series) works properly. Allow half an hour warm-up prior to conducting the performance test.

3.1 Performance Test Procedure

Verify the following points:

External view

1. Adjust the leveling feet to level the balance. Confirm it using the bubble spirit level.
2. The weighing pan should be level. (Check for the correct pan assembly.)
3. Use the breeze break for GX-200/400/600 and GF-200/300.

Functions

1. Verify that each key functions correctly:

ON/OFF key

CAL key

PRINT key

RE-ZERO key

SAMPLE key

MODE key

2. Verify that the followings operate correctly:

The minus indicator

The decimal point indicator

A stable weighing data can be obtained

The motor functions properly without noise

External key inputs function in the RS-232C connector

The RS-232C communication function

Date and time accuracy (\pm Two minutes in error)

Selection of the weighing units

Identifies each of three TLs.

Evaluates the factor k using a 1000-g weight (1000.00 g) on GX-2000 for instance.

e.g. when "26.4555 TL" is displayed,

$$k = \text{g display} / \text{TL display} = 1000.00 / 26.4555 = 37.799$$

3. Verify that the TAEI values are within tolerance :

		Weight	Tolerance
Hong Kong (jewelry)	TN	1 TAEI = 37.4290 g	37.428-37.430 g
Hong Kong (general) Singapore	TG	1 TAEI = 37.7994 g	37.798-37.800 g
Taiwan	TT	1 TAEI = 37.5000 g	37.499-37.501 g

3.2 Test Details

Internal mass repeatability (Only for GX)

After auto calibration by pressing **[CAL]** key, place the specified mass on the pan and read the displayed value. Repeat this procedure three times. Verify that the difference between the maximum value and the minimum value is within the specifications.

Model	Masses	Specifications
GX-200	200g	±0.010g
GX-400	400g	
GX-600	500g	
GX-2000	2kg	±0.10g
GX-4000	4kg	±0.15g
GX-6100	5kg	
GX-6000	5kg	±0.5g
GX-8000	5kg	

External mass calibration (Only for GF)

After external mass calibration by pressing **[CAL]** key, place the specified mass on the pan and read the displayed value. Verify that the difference between the maximum value and the minimum value is within the specifications.

Model	Masses	Specifications
GF-200	200g	±0.002g
GF-300	200g	
GF-1200	1kg	±0.02g
GF-2000	2kg	
GF-3000	2kg	
GF-6000	5kg	±0.2g

Repeatability

Place the specified mass at the center of the pan and remove. Record the displayed values with and without load. Repeat the test ten times (one set). Get 10 span data with subtracting the displayed value when no load is applied from the displayed value when load is applied. Obtain the standard deviation from the 10 data and verify that it is within the specifications. If not, perform another two sets of test and obtain the standard deviation for each set. Verify that the two standard deviations are within the specifications.

Model		Masses	Specifications
GX-200	GF-200	200g	0.001g (standard deviation)
	GF-300	300g	
GX-400		400g	
GX-600		600g	
	GF-1200	1kg	0.01g (standard deviation)
GX-2000	GF-2000	2kg	
	GF-3000	3kg	
GX-4000		4kg	
GX-6100		6kg	
GX-6000	GF-6000	6kg	0.1g (standard deviation)
GX-8000		8kg	

Corner load error

Place the specified mass at the center of the pan (1) and record the displayed value. Then place the mass, at positions 2, 3, 4, 5 then 6. Verify that the difference between the values at the center and at each position (the cross marks 2, 3, 4, and 5 are half the distance from the center of the pan to the corner edge) is within the specifications.

Model		Masses	Specifications
GX-200	GF-200	100g	$\pm 0.003g$
GX-400	GF-300	200g	$\pm 0.004g$
GX-600		300g	$\pm 0.004g$
GX-2000	GF-1200/ GF-2000	1kg	$\pm 0.03g$
GX-4000	GF-3000	2kg	$\pm 0.04g$
GX-6100		3kg	$\pm 0.05g$
GX-6000	GF-6000	4kg	$\pm 0.3g$
GX-8000		4kg	$\pm 0.2g$

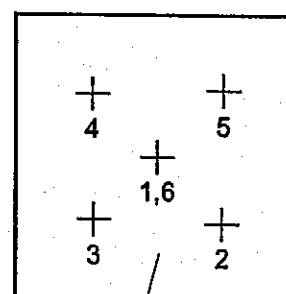

Weighing pan

Linearity / Hysteresis

After calibration by using an external weight of almost weighing capacity, place the specified mass one by one on the pan, and check the difference between true value and display value (linearity). After reaching weighing capacity, remove the mass one by one, and check the difference between an increase and decrease (hysteresis).

Model		Masses	Linearity	Hysteresis
GX-200	GF-200	100g×2	±0.002g	±0.002g
	GF-300	100g×3	±0.002g	±0.002g
GX-400		100g×4	±0.002g	±0.002g
GX-600		200g×3	±0.003g	±0.003g
	GF-1200	500g×2	±0.002g	±0.03g
GX-2000	GF-2000	1kg×2	±0.02g	±0.03g
	GF-3000	1kg×3	±0.02g	±0.03g
GX-4000		1kg×4	±0.02g	±0.03g
GX-6100		2kg×3	±0.03g	±0.04g
GX-6000	GF-6000	2kg×3	±0.1g	±0.2g
GX-8000		2kg×4	±0.1g	±0.2g

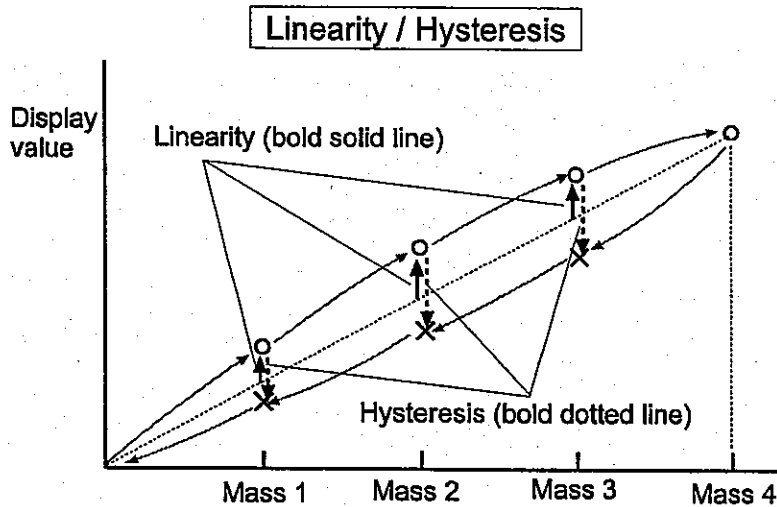

4. Corrective Maintenance

Perform corrective maintenance for the GX/GF series by referring to the maintenance flowchart and the troubleshooting table. The troubleshooting table describes the possible cause and solution to facilitate corrective maintenance.

Perform corrective maintenance according to the error (the letters refer to nodes on the maintenance flow chart):

Type A: Replacing, disassembling, or assembling the force motor unit

Type B: Replacing or adjusting electrical parts

Type C: Initializing a electric board and inputting specific data

Type D: Adjusting the characteristics of the force motor unit

Type E: Inputting temperature data

Type F: Performance test

Type G: Performing drift check

4.1 Troubleshooting Table

The following troubleshooting table describes the possible cause of, and the solution to problems.

Problem	Cause	Check	Solution	Type
No display, beam is not balanced	AC adapter	Is it the correct AC adapter for the power source used.	Replace with the correct AC adapter.	F
		Is the output voltage correct? Measure the output voltage of the AC adapter with it connected to the balance. The DC output should be at least 14 volts, but no greater than 22 volts.	If the output voltage is not correct, replace the AC adapter.	F
	Fuse	Disconnect the AC adapter and measure the fuse with an ohm meter.	Replace with the correct fuse.	F
	Power supplies of main board	Is the output of the each power supplies correct? (Refer to Table-1 of page 12) Check the V _{dd} , V _{ee} , V _{cc} , V _f , V _{vfd} , V _m	Check (replace) the main board with substitute items.	H
			Check (replace) a defective power supply part with a substitute item.	F
	Force motor	Check that the connectors are installed correctly. (J11, J11A)	Replace the force motor with a substitute item. (Refer to "5. Force Motor Disassembly and Reassembly")	A
	Main board assembly (CPU, Gate array is contained)	Check the performance using the standard main board that works properly.	Replace the main board assembly with a substitute item.	H

Problem	Cause	Check	Solution	Type
Unstable weighing data, repeatability error	Force motor, AMZ51	Check the operation of weight / temperature offset A/D. (Refer to "6-13 Method of identifying defect location") If it is [CH na], the cause will be the AMZ51.	Replace the AMZ51	E
		Then if it is OK, the cause will be the force motor.	Check the force motor	A
	Pan assembly	Check that the pan assembly is correctly installed	Install the pan assembly correctly.	F
		Check for foreign matter between the pan and breeze break frame.	Clean the area around the pan assembly and the breeze break frame.	F
		Check that the breeze break frame does not touch the pan assembly.	Install the breeze break frame correctly so that it does not touch the pan.	F
	Damage in flexures	Check the condition of tension and fulcrum flexures.	Replace the parts and reassemble the force motor.	A
	Magnet assembly	Check for dust particles between the magnet and the force coil.	Clean the force motor assembly. (Refer to "5. Force Motor Disassembly and Reassembly")	A
Force motor assembly	Check that the flexures are in good conditions and are correctly installed.	Repair the force motor assembly. (Refer to "5. Force Motor Disassembly and Reassembly")	A	
Corner load error	Force motor assembly	Check that the flexures are in good conditions and are correctly installed.	Perform corner load adjustment. If it does not work well, disassemble and reassemble the balance. (Refer to "5. Force Motor Disassembly and Reassembly")	A
Hysteresis error	Tension or Fulcrum flexures	Check the condition of tension and fulcrum flexures for distortion.	Replace with substitute items. disassemble and reassemble the balance. (Refer to "5. Force Motor Disassembly and Reassembly")	A
Linearity error	Force motor assembly	Follow the linearity check procedure.	Input the linearity data. Refer to page 37.	F
After calibrated using the internal mass, the weighing data is not correct (Only GX)	Force motor assembly	After auto calibration using the internal mass, check the value using the specified mass.	Fine adjustment of the linearity. Refer to page 40.	F

Problem	Location	Check	Solution	Type
<i>Error 0</i> Temperature data error	Temperature sensor, AMZ51, Cables, connectors	Check the operation of weight / temperature offset A/D. (Refer to "6-13, 2 Method of identifying in the internal offset mode")	In the T1 display of check mode menu, check the absolute value and dispersion (Refer to 6-7). If it is NG further, replace and reassemble temperature sensor.	B
		Then if it is NG, the cause will be the AMZ51.	Replace the AMZ51.	E
<i>Error 1</i> Unstable weighing data	Force motor, AMZ51	Check the operation of weight / temperature offset A/D. (Refer to "6-13 Method of identifying defect location") If it is OK, the cause is the force motor.	Check the force motor.	A
		Then if it is NG, the cause will be the AMZ51.	Replace the AMZ51.	E
[H nG] (Only GX) Result of automatic environment setting	Pan assembly	Check that the pan assembly is correctly installed.	Install the pan assembly correctly.	F
		Check for foreign matter between the pan and breeze break frame.	Clean the area around the pan assembly and the breeze break frame.	F
		Check that the breeze break frame does not touch the pan assembly.	Install the breeze break frame correctly so that it does not touch the pan.	F
	Damaged flexures	Check the condition of tension and fulcrum flexures.	Replace the parts and reassemble the force motor unit.	A
	Magnet assembly	Check for dust particles between the magnet and the force coil.	Clean the force motor assembly. (Refer to "5. Force Motor Disassembly and Reassembly")	A
	Weighing error relating to calibration	Check if <i>Error 1</i> appears due to underloading (-E) during automatic zero adjustment after the balance is turned on.	Calibrate.	F
<i>Error 3</i> Defective EEPROM	Defective EEPROM on the Main board	Bad connection between CPU (U1) and EEROM (U3, U4, U14) Check the soldering around each IC. * GF models have no U3 and U14.	Re-solder	F
			Replace the CPU (U1)	F
			Replace the EEPROM (U3, U4, U14)	H
			Note After replacing the CPU or EEPROM, <i>Error 8</i> , <i>Error 9</i> or <i>Error A</i> may be displayed. To correct the error, see the solution for each error described in this table.	-
<i>Error 4</i> RAM error in CPU	Defective CPU on the Main board	Defective RAM in CPU.	Replace the CPU (U1).	F

Problem	Cause	Check	Solution	Type
Error 6 (Only GX) Internal mass operation error, D0 value error	Pan assembly	Check that the pan assembly is correctly installed.	Install the pan assembly correctly.	F
	Weighing pan	Check that nothing is placed on the pan when the internal mass moves during the display on and off or power-on.	Make sure that nothing is placed on the pan.	F
	Internal mass assembly	Check that the internal mass is in place and that it can be raised or lowered.	Check the internal mass. Apply grease to the movable parts (five places) of the internal mass assembly.	F
Error 7 (Only GX) Cam detection error	Defective motor	Remove the motor and check if it rotates correctly.	Replace the motor.	F
	Cam position	Re-position the cam. (Check if the motor is overloaded)	Install the cam in the correct position.	F
	Relative position of the slit and photo interrupter	Check that the motor rotation stops correctly.	Install correctly.	F
Error 8 EEPROM error	CPU (U1) and EEPROM (U3,U4,U14) on the main board	The EEPROM version is not correct for the newer CPU version.	Press the PRINT key to change the EEPROM version.	F
Error 9 EEPROM format error	CPU (U1) and EEPROM (U3,U4,U14) on the main board	EEPROM has not been initialized.	While holding down the RE-ZERO and MODE keys, press the PRINT key to initialize the EEPROM.	C
Error A EEPROM version error	CPU (U1) and EEPROM (U3,U4,U14) on the main board	The EEPROM version is not correct for the older CPU version.	While holding down the RE-ZERO and MODE keys, press the PRINT key to initialize the EEPROM.	C
CAL E -CAL E Calibration range error	The mass exceeds the calibration range	Check that the correct mass is used for calibration.	Use the correct mass.	F
	AMZ51,coil, zero or span	Check the D0 value.	If the D0 value is not within the specifications, replace parts and reassemble. (When the D0 value is correct, perform calibration in check mode)	A

Problem	Cause	Check	Solution	Type
E Overload	Weighing error relating to calibration	Check the D0 value	When the D0 value is correct, perform calibration in check mode, then perform calibration in the weighing mode	F
	Stopper position, Damage in flexures	Check the D0 value	If the D0 value is not within the specifications, adjust the stoppers, replace flexures and reassemble	A
-E Underload	Weighing pan	Check if the correct pan is used and that the pan is installed correctly	Use the correct pan and install it correctly	F
	Weighing error relating to calibration	Check the D0 value	When the D0 value is correct, perform calibration in check mode, then perform calibration in the weighing mode	F
	Stopper position, Damage in flexures	Check the D0 value	If the D0 value is not within the specifications, adjust the stoppers, replace flexures and reassemble	A
rtc PF (Only GX) Or gap at date and time	Defective battery for clock	Check if the voltage at both ends of R20 is 3.3mV or less. Check if the voltage between the minus side of lithium-battery and the cathode side the diode (D6) is 2.5V or more	If the voltage is lower, replace the lithium-battery and set the clock data. (After setting the clock data, do not touch the lead leg of X2 by tool or hand)	F
EH no	AMZ51	In case of EH no is displayed by the self check function	Replace the AMZ51	E

Table-1 Specifications of each power-supply voltages on the main board

Circuit symbol	Specifications	Check point	Voltage generation element
Vdd	5.3V – 4.7V	At both ends of C45	U15
Vee	-5.3V – -4.7V	At both ends of C11	U10, U11
Vcc	10.4V – 9.6V	Between the minus side of C11 and the plus side of C10	U10, U11
Vf	2.7V – 2.4V	At both ends of display part (2pin – 39pin)	U8
Vvfd	26V – 23V	At both ends of C26	U9
Vm	6.3V – 5.8V	At both ends of C28	U12 (Only GX)

4.2 Maintenance Flowchart

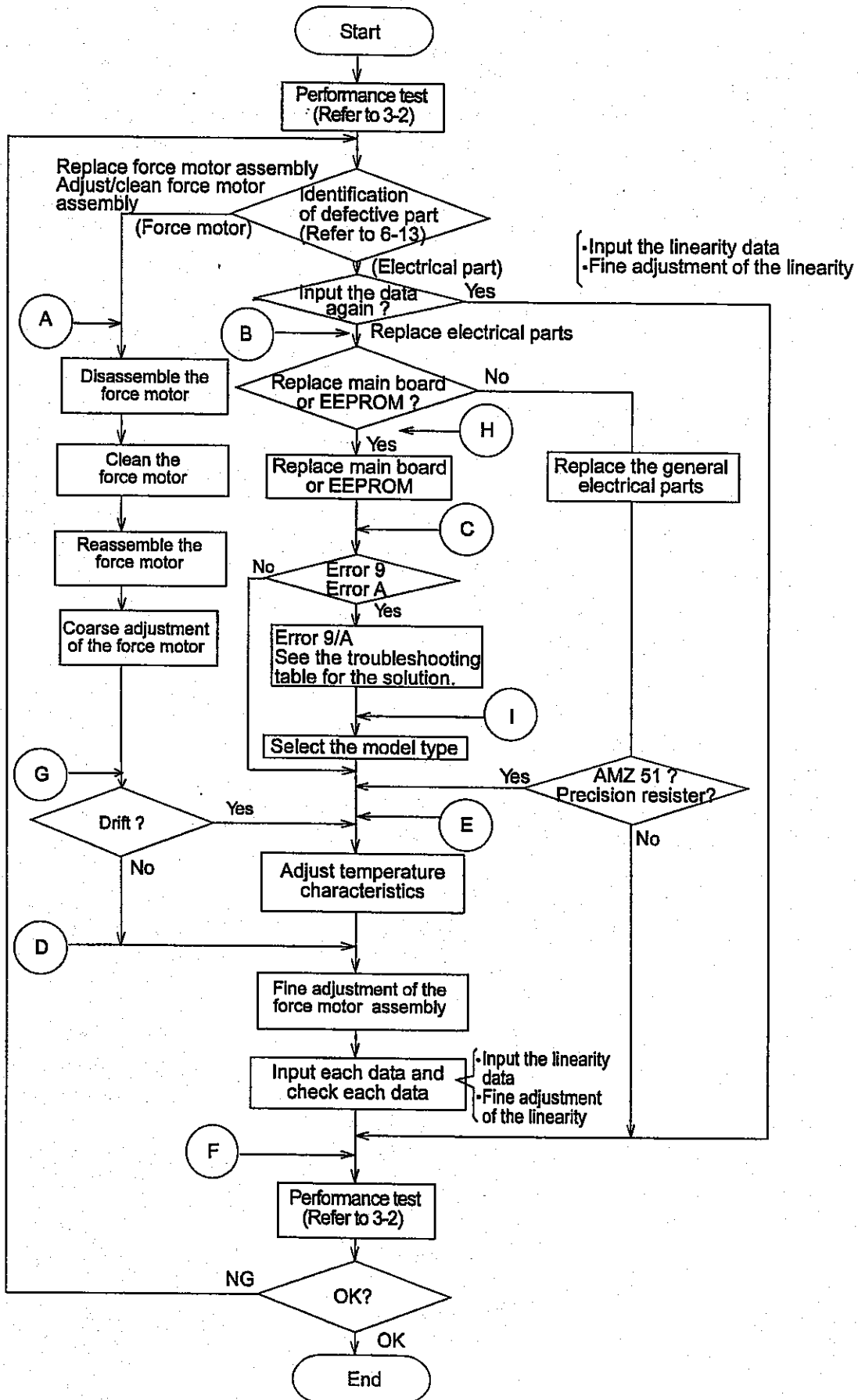

5. Force Motor Disassembly and Reassembly

This chapter describes the procedures and notes for the flexure assembly replacement, bobbin cleaning, and adjustment after reassembling the force motor.

Notes: It should be a dust free environment for disassembly and reassembly. Adjustments and confirmations are needed after reassembly for linearity, repeatability, creep, hysteresis and corner load error.

Temperature adjustment is also needed since the balance is affected by tightening torque or stress. If you do not have the proper facilities to do the temperature adjustment, do not attempt to adjust the temperature feature.

A set of jig for GX/GF force motor disassembly and reassembly

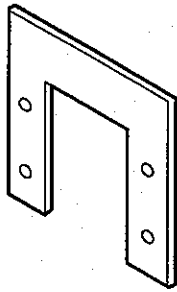

A board for positioning the beam (GX-1/6)

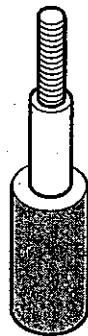

A bolt for holding the beam (GX-3/6)

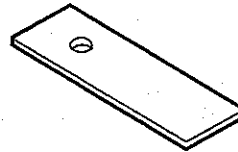

A spacers for positioning the beam (2 pcs) (GX-4/6, 5/6)

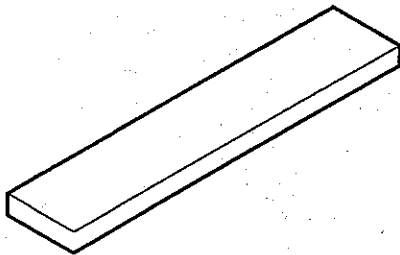

A spacer for positioning roberval (GX-2/6)

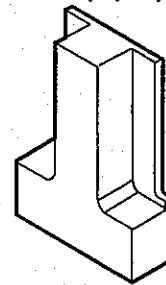

A jig for positioning fulcrum flexure (GX-6/6)

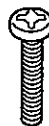

Pan head screws M4 X 8 (2 pcs)
M4 X 12 (2 pcs)

● Other tools required:

- A level block
- A square
- A screwdriver, 3mm
- An allen wrench, 3mm, 6mm
- A soldering iron

5.1 Disassembly

1. Removing the upper case

Note: There are three types of mechanical system among GX/GF models as shown below.

Model		Systems
GX-200/400/600	GF-200/300	600 systems
GX-2000/4000/6100		6100 systems
GX-6000/8000	GF-1200/2000/3000/6000	8000 systems

- ① Remove the weighing pan. In case of 6100/8000 systems, remove the breeze break frame, too.
- ② Remove the pan support receptors from the main unit.
- ③ Remove the screws (pan head screw (M4 X 10) + toothed lock washer...2 pcs) from the rear side.
- ④ Open the upper case by sliding it forward a little.
- ⑤ When removing the upper case, disconnect the connector on the switch board.

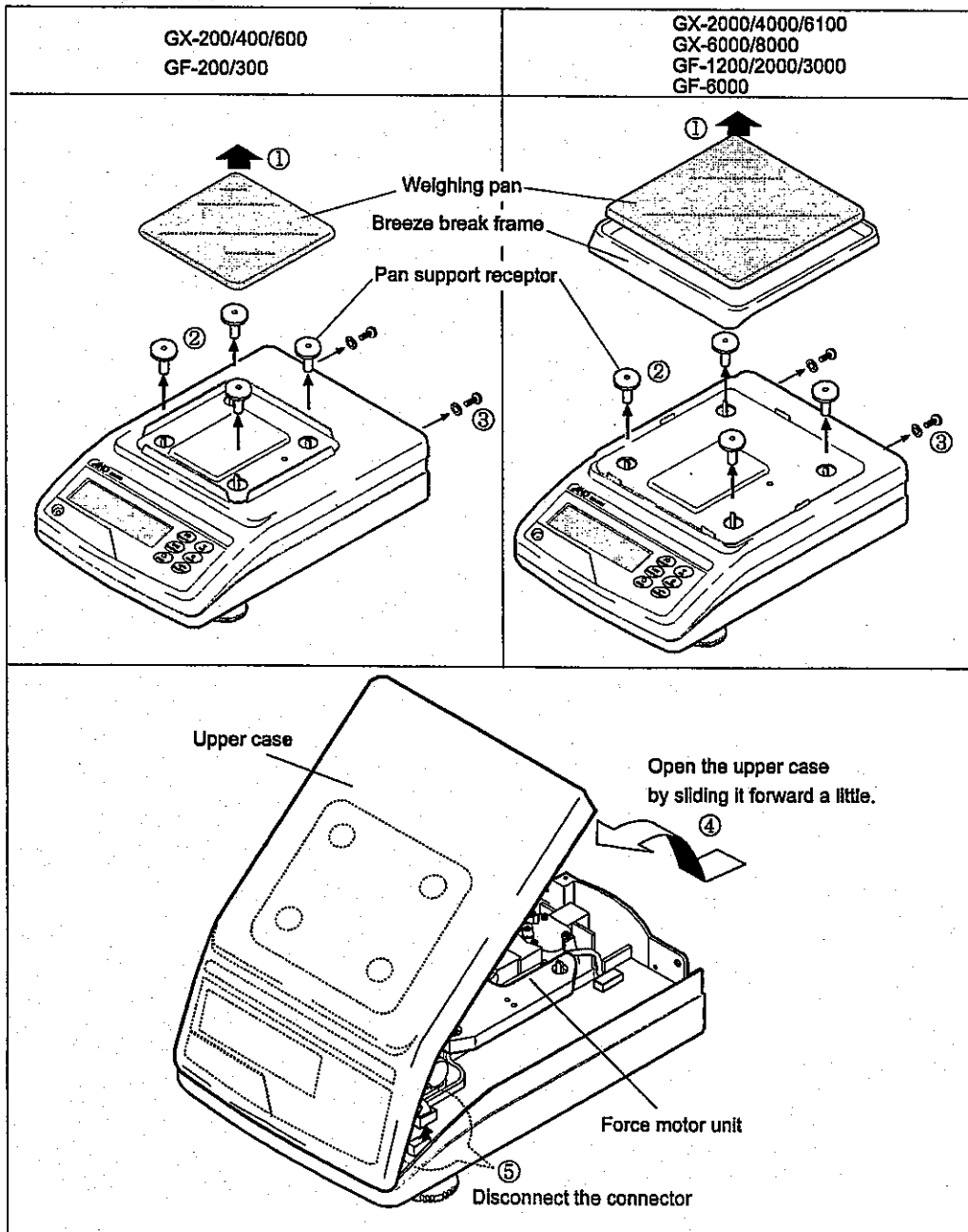

2. Removing the force motor unit

- ① Remove the pan support arm. (600 systems-pan head screw (M4 X 8), 6100/8000 systems-allen head screw (M4 X 8) + coned disk spring...2 pcs)
- ② (Only GX) Remove the internal mass limiter and internal mass. (pan head screw with spring and plain washer (M4 X 6)...2 pcs)
- ③ Disconnect the main board cable.
- ④ Remove the force motor. (allen head screw (M4 X 10) + toothed lock washer...4 pcs)

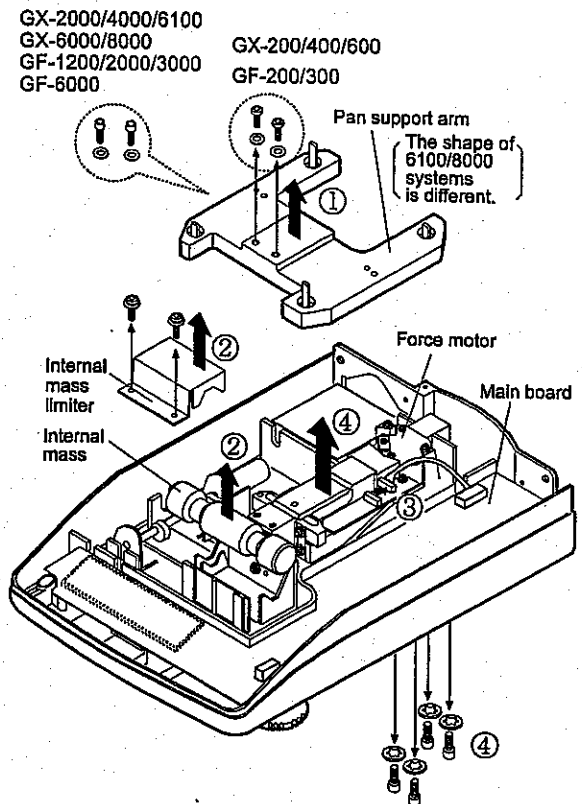

3. Disassembling the force motor

- ① (Only GX) Remove the Internal mass hook. (Pan head screw with spring and plain washer (M4 X 6)...2 pcs)
At this time, remove the screws holding the internal mass hook.
- ② Remove the shield plate. (Pan head screw with spring and plain washer (M3 X 6)...2 pcs)
- ③ Remove the position sensor unit. (Pan head screw with spring and plain washer (M3 X 12)...2 pcs)
- ④ Remove the yoke. (Pan head screw with spring and plain washer (M4 X 12)...2 pcs)
- ⑤ Remove the wires on the beam side, using a soldering iron.

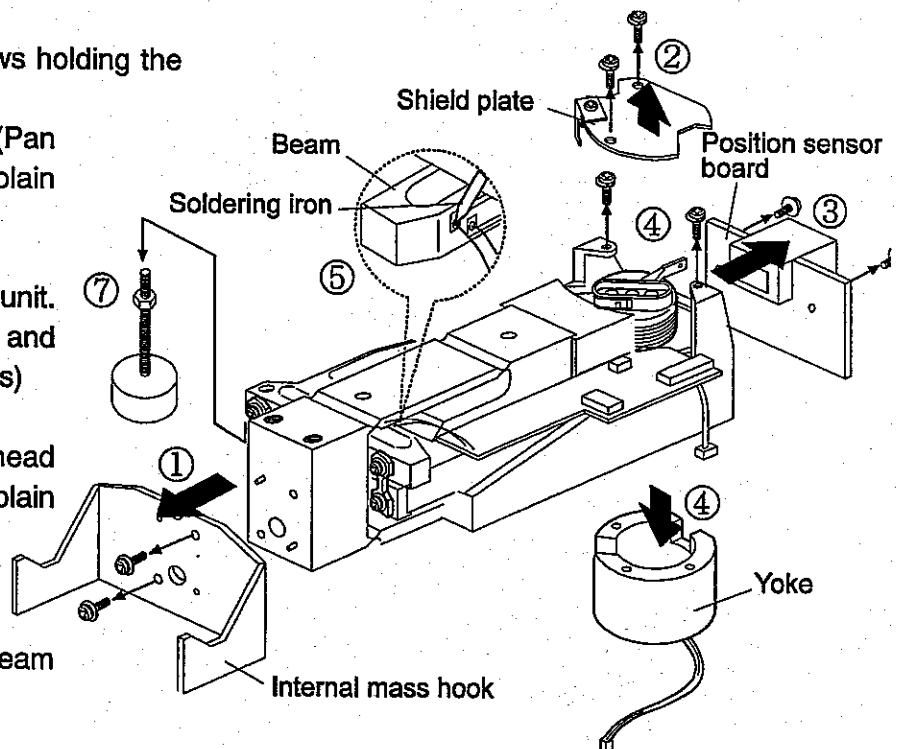

- ⑥ Secure the beam using the spacers for positioning beam (2 pcs) and the bolt for holding beam.
- ⑦ Remove the trimming mass unit.

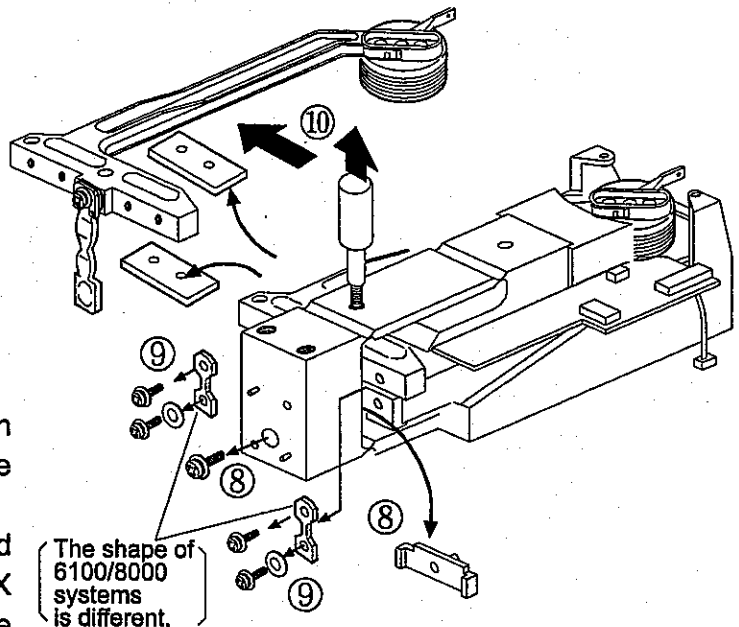
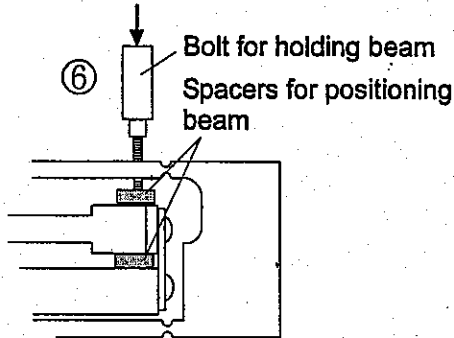

- ⑧ Remove the screw from the tension flexure and tension flexure holder on the robarval side.
- ⑨ Remove the fulcrum flexures. (pan head screw with toothed washers (M4 X 10)...2pcs, Pan head screw with distance ring and coned disk washer (M4 X 10)...2pcs)
- ⑩ Remove the beam holding bolt and the beam positioning spacers (2 pcs).
Remove the beam.
Note : When assembling, return the shim to the original place.

4. Disassembling the beam unit

- ① Remove the tension flexure. (pan/ truss head screw (M4 X 8) + coned disk washer)
- ② Remove the wire of the bobbin using a soldering iron.
- ③ Remove the bobbin. (pan head screw (M3 X 4)...2 pcs, brass, no-plating)

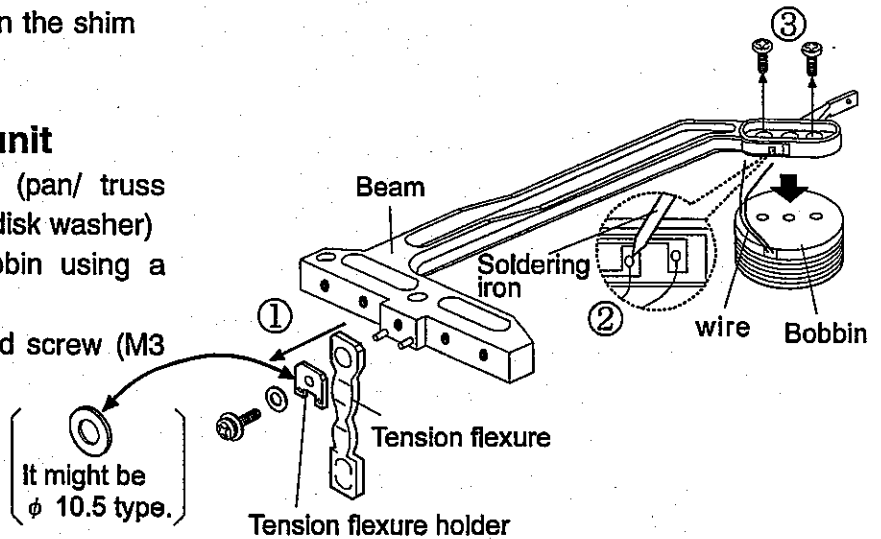

5. Disassembling the frame

- ① Remove the relay board and board spacer. (pan head screw with spring and plain washer (M3 X 6), (M3 X 10)...2 pcs)
- ② Remove the robarval from the frame. (Allen head screw with spring and plain washer (M6 X 20)...2 pcs)

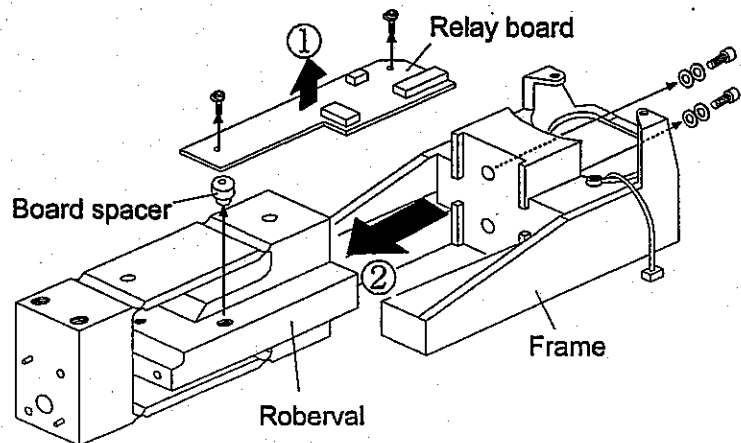

5.2 Cleaning the Magnet Assembly and Bobbin

The magnet assembly and the bobbin will require cleaning if the balance has a repeatability problem. Particles of metal, dust or other foreign material can collect around the bobbin. If such material touches the bobbin, the bobbin will not move correctly. Metal particles are attracted to the magnet and tend to stand straight out. The gap for the bobbin is very narrow, so be very cautious while removing particles.

Note: Do not use compressed air to blow out the magnet well. There may be particles of magnetic material stuck to the bottom of the magnet.

The tools that you use near the magnet should be free of plating and non-magnetic. A flake of plating or a metal particles will be attracted to the magnet.

The screws used in this balance are non-magnetic. Do not substitute screws made of magnetic material.

- ① Prepare a 5 cm-long adhesive tape for cleaning. Use a paper backed or cloth tape (do not use a tape that can be torn easily, such as cellophane tape, it may stick to the magnet and be very difficult to remove).
- ② Clean around the inner and outer surfaces of the magnet well using the adhesive tape.
- ③ Clean the inner and outer surfaces of the bobbin using the adhesive tape.
- ④ Inspect the magnet well and bobbin using a very strong light. Look for any particles stuck to the surfaces. Metal particles may be shiny or dark. Look for anything stuck out from the sides of the magnet.
- ⑤ Reassemble the force motor and test it for repeatability. Corner load error can often be traced to a repeatability problem.

If there is still a problem, disassemble the force motor and check closely for particles in the magnet gap.

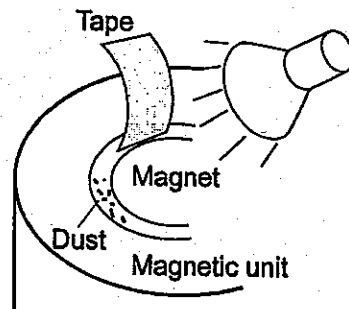

5.3 Reassembly

1. Reassembling the beam unit

- ① Install the bobbin. (pan head screws (M3 X 4)...2 pcs, brass, no-plating)
- ② Solder the bobbin wires to the flexible printed circuit.
Cut the excess wire if necessary.
Secure the wires running on the bobbin with the adhesive.
- ③ Place the beam upside-down on the flat board. Install the tension flexure perpendicularly and pull it up as far as possible*.
Tightening torque...14kgf · cm (pan/ truss head screw (M4 X 8) + coned disk washer)

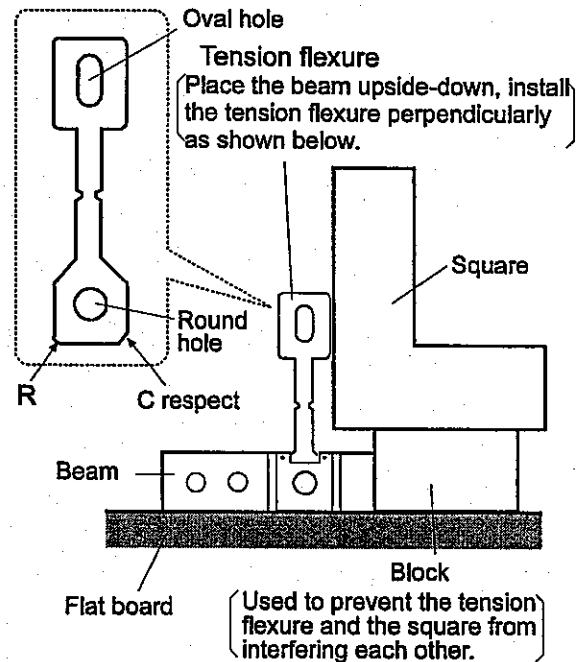
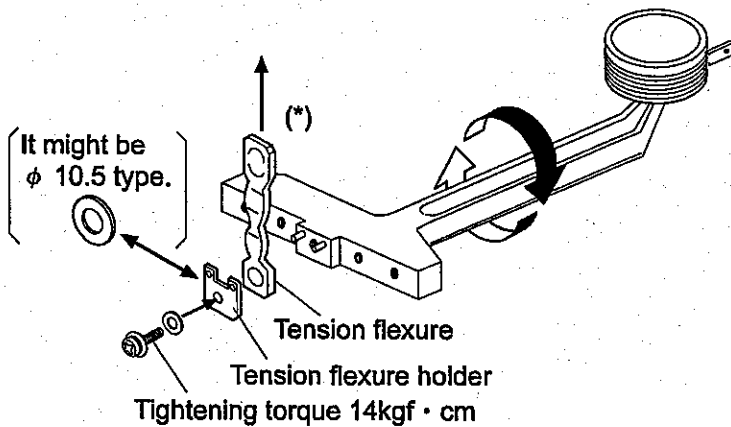
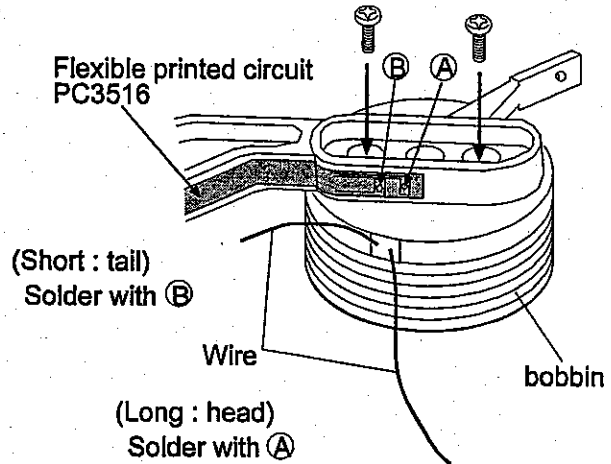

2. Reassembling the frame unit

- ① On the level block, install the roberval in the frame using the roberval positioning spacer. Tightening torque...60kgf · cm (Allen head screw with spring and plain washers (M6 X 20)...2 pcs)

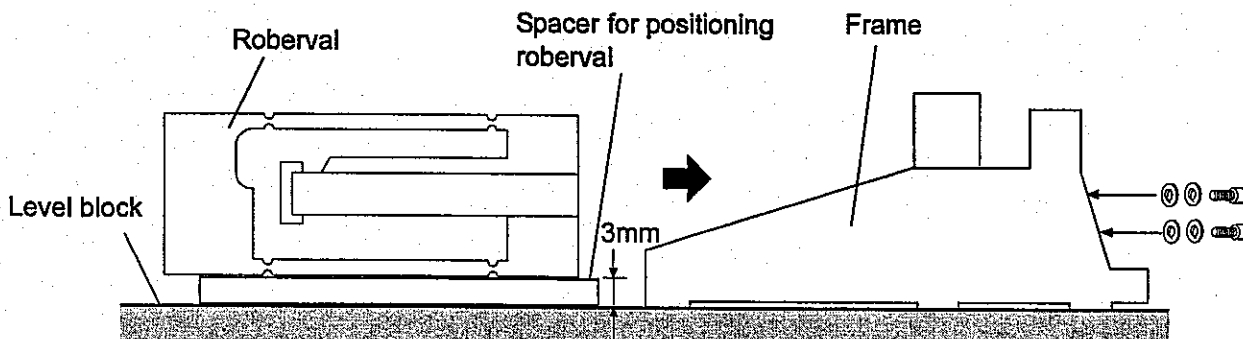

- ② Place the board spacer, and install the relay board. (Pan head screw with spring and plain washer (M3 X 6), and (M3 X 10))

3. Reassembling the force motor unit

- ① Secure the beam temporarily by using the spacers for positioning beam and the beam holding bolt.
- ② Secure the installation side of the robarval and the fulcrum flexures of the beam using the board for positioning fulcrum. At this time, confirm that the screw holes of the tension flexure and the screw holes of the robarval put in order.

- ③ Fasten the beam holding bolt tightly.
- ④ Remove the board for positioning beam, and install the fulcrum flexures. In the case of the 6100/8000 systems, use the jig for positioning fulcrum.

Tightening torque...14kgf · cm

Beam side: Pan head screw with toothed washers (M4 X 10)...2pcs

Roberval side: Pan head screws with distance ring and coned disk washer (M4 X 10)...2pcs

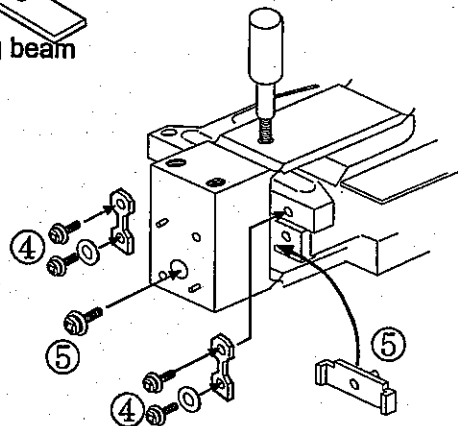
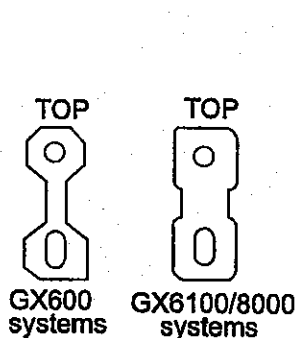
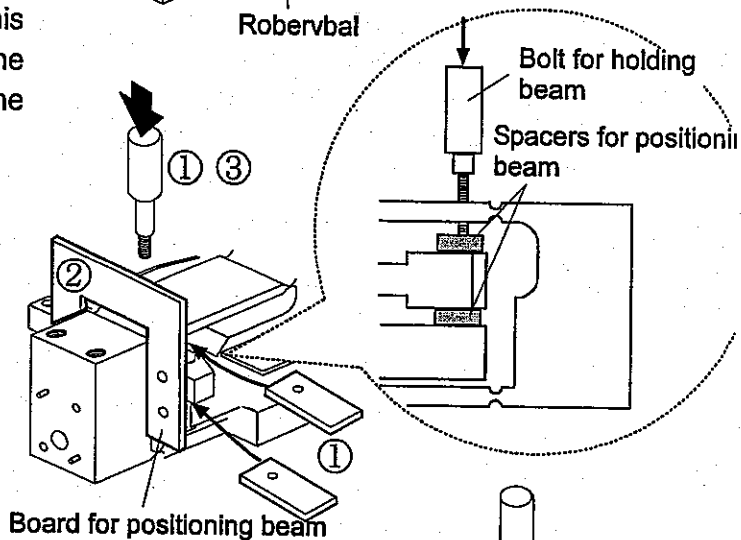
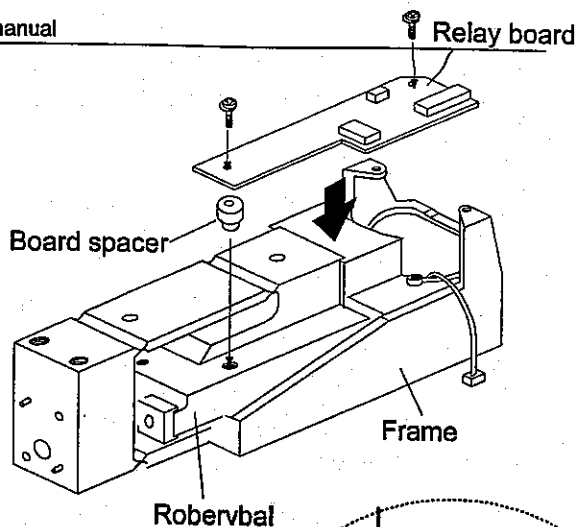

- ⑤ Attach the tension flexure to the robarval using the tension flexure holder.

600 systems: Pan head screw (M4 X 20) + coned disk washer

6100/8000 systems: Pan head screw (M4 X 25) + coned disk washer

- ⑥ Secure the yoke temporarily after cleaning the yoke and the bobbin. (Pan head screw with spring and plain washer (M4 X 12)...2 pcs)

- ⑦ Install the trimming mass unit.
Position (A) of the trimming mass unit
600systems...18mm, 6100/8000 systems...23mm

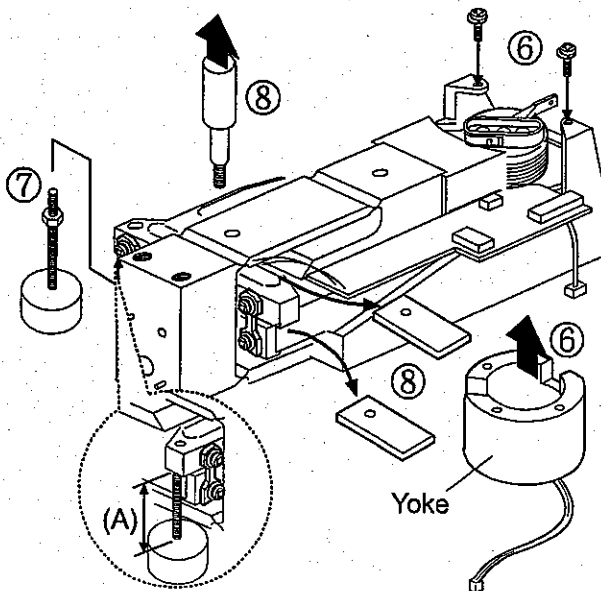

- ⑧ Remove the bolt for holding beam and the spacers for positioning beam (2 pcs).
- ⑨ Adjust the position of the yoke so that the center of the yoke can meet the center of the bobbin.
- ⑩ Install the shield plate. (Pan head screw with spring and plain washer (M3 X 6)...2 pcs)
- ⑪ Install the position sensor unit. Secure the upper surface of position sensor holder by holding it against the convex part of shield plate. (Pan head screw with spring and plain washer (M3 X 12)...2 pcs)
- ⑫ Solder the wires to the beam from the relay board. At this time, secure that the top of the wires are lower than the pan support arm.
- ⑬ (Only GX) Install the internal mass hook. (Pan head screw with spring and plain washer (M4 X 6)...2 pcs) At this time, secure the screws holding the internal mass hook.

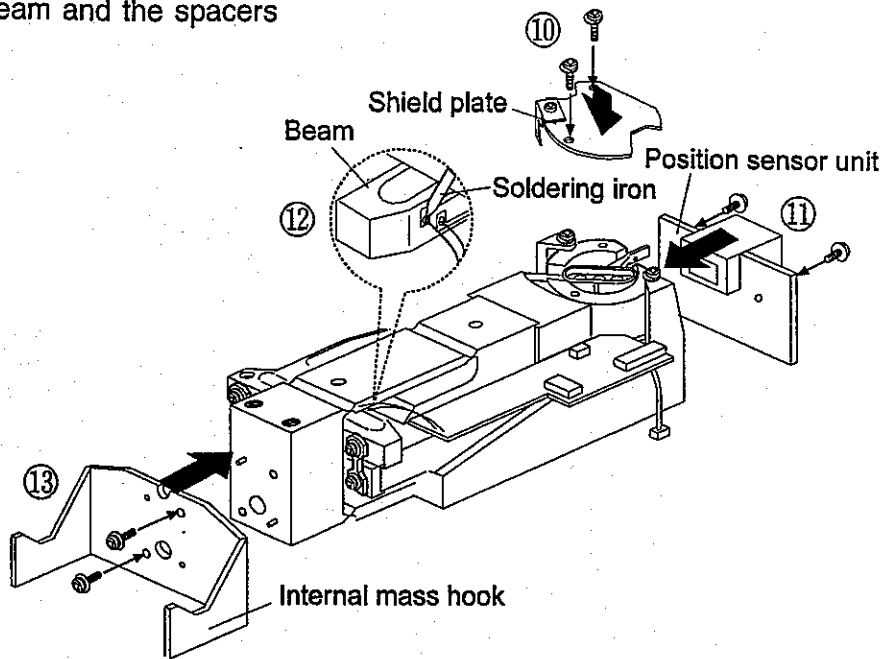

4. Installing the force motor unit

- ① Install the force motor unit into the lower case. About the position front to rear, secure the rear end of force motor unit by holding it against the rib of lower case unit. About the position side to side, secure to be level by visual inspection. Tightening torque...30kgf · cm (allen head screw (M4 X 10) + toothed lock washer...4 pcs)
- ② Connect the main board cable to the relay board connector.
- ③ (Only GX) Install the internal mass and the internal mass limiter. When installing the internal mass limiter, be careful to place it in the correct position. (Pan head screw with spring and plain washer (M4 X 6)...2 pcs)
- ④ (Only GX) By moving the force motor unit back and forth, adjust its position so that the internal mass will be pressed against the internal mass limiter.

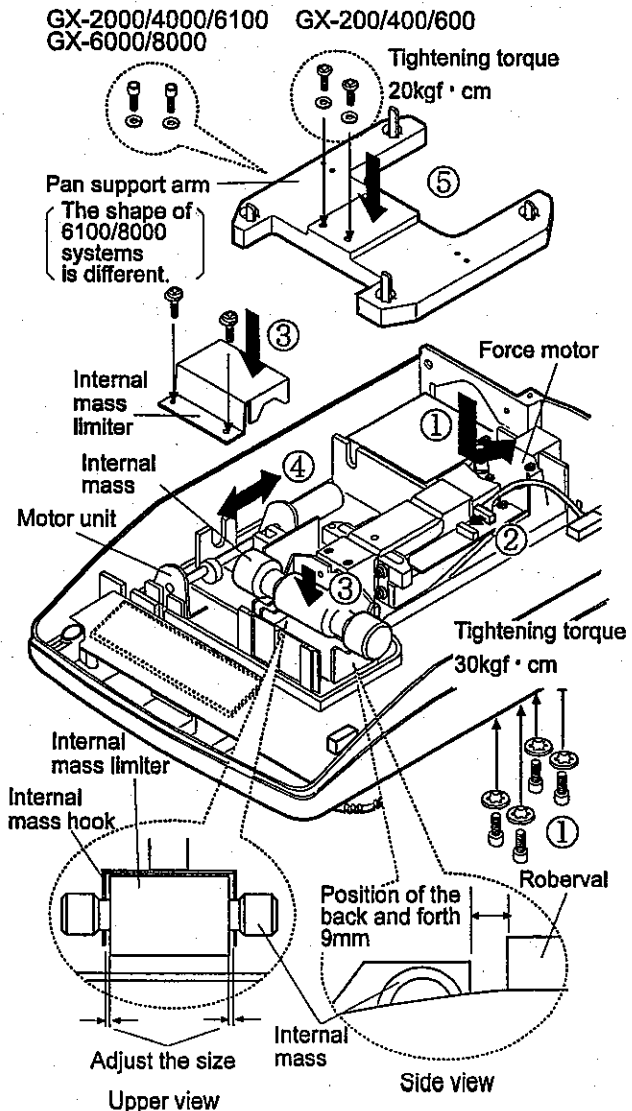



- ⑤ Secure the pan support arm level by visual inspection.
Tightening torque...20kgf · cm
600 systems: Pan head screw (M4 X 8) + coned disk washer...2 pcs
6100/8000 systems: Allen head screw (M4 X 8) + coned disk washer...2 pcs

5. Installing the upper case unit

- ① Connect the switchboard cable connector. Install the upper case by catching the convex part of the lower case.
- ② Secure the two screws from the rear side of the balance. (Pan head screw (M4 X 12) + toothed lock washer...2 pcs)
- ③ Screw in the pan support receptor to secure.

Note:

Install the pan support receptor so that the upper convex is to the inside. ( : Figure with the convex part)

For the right front position, use the one without the convex part. ( : Figure without the convex part)

New pan support receptors have a convex part. Remove it before using for the right front position.

For the right front and the left rear, push the pan support receptor onto the shock absorber so that the top of the shock absorber protrudes from the pan support receptor. (In case of the 600 systems, the spring of the shock absorber is weak. Therefore, hold the outer part of the pan support receptor and insert the pan support receptor while turning it to the right and to the left.)

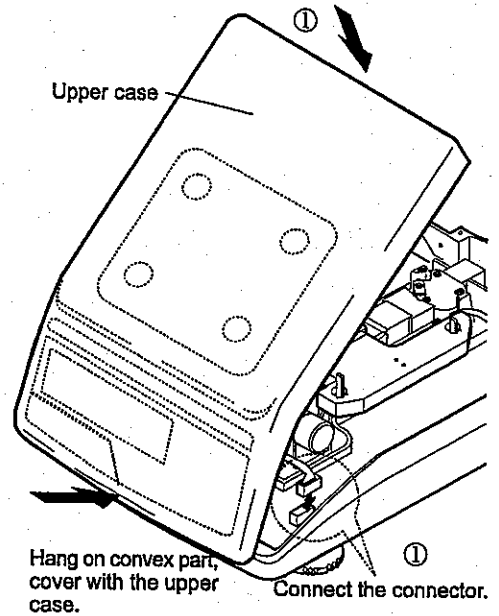
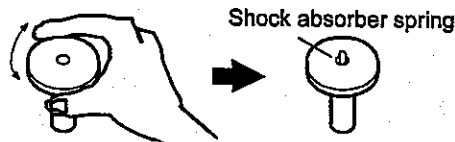

- ④ Place the weighing pan on the balance.

Note: In case of the 6100/8000 systems, install the breeze break frame.

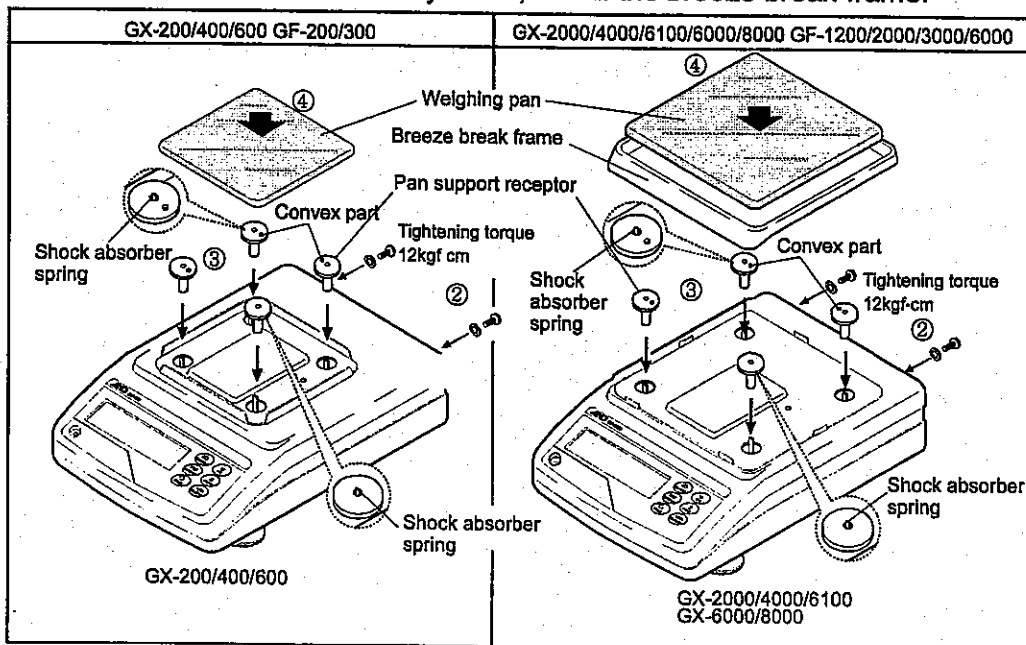

6. Adjustments

6.1 Adjustment Flow Chart

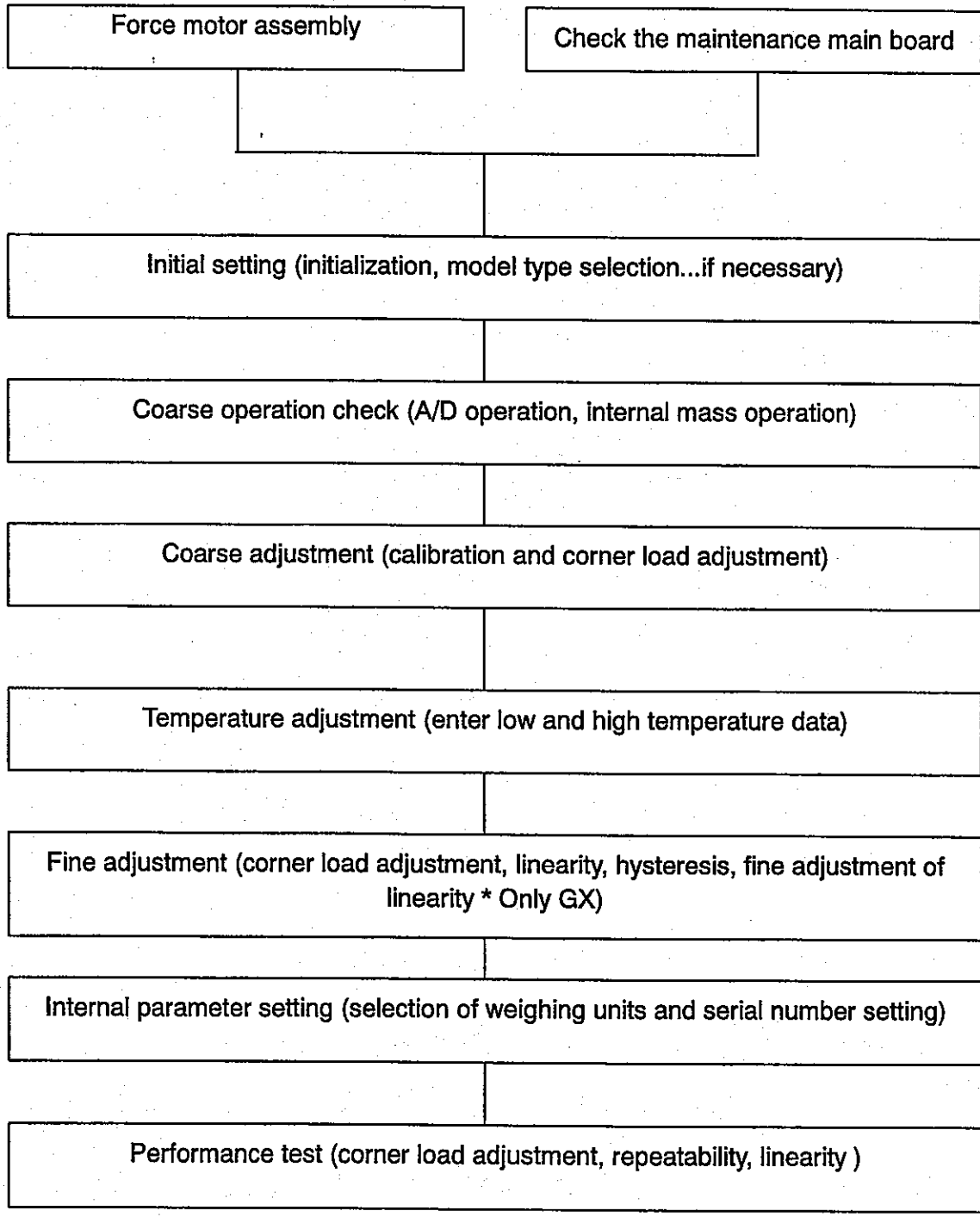

6.2 General Precautions

The data structure is shown below. Functions listed nearer to the bottom are more basic. If the specific data is adjusted, all data listed above the adjusted data must also be adjusted.

GX Series

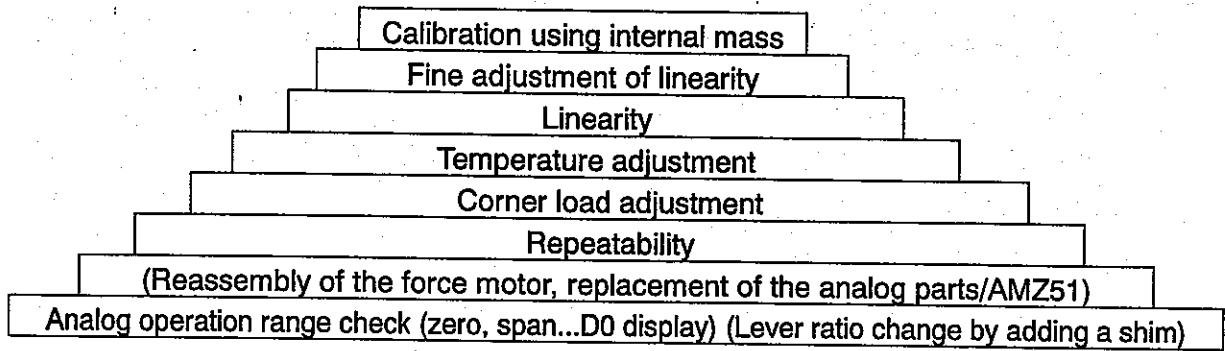

GF Series

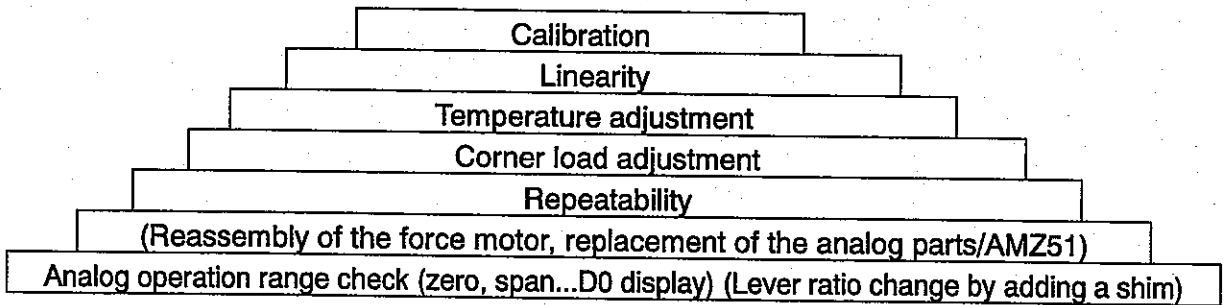

6.3 Check Mode

Check mode consists of three modes: Data adjustment mode, function setting mode and basic setting mode.

1. Entering the check mode

- Step 1. Verify that the display is OFF.
- Step 2. Press and hold the **RE-ZERO** and **MODE** keys and press the **ON/OFF** key. Release the **MODE** and **ON/OFF** keys while still holding the **RE-ZERO** key. Immediately press the **MODE** key twice. Perform this procedure within 2 seconds.
- Step 3. The software version will be displayed for about 1 second **P- X.XX**.
- Step 4. The balance model type will be displayed **2000 Gx**. (The model type displayed depends on each actual model.)
- Step 5. All of the display segments will turn on.

2. Check mode menu

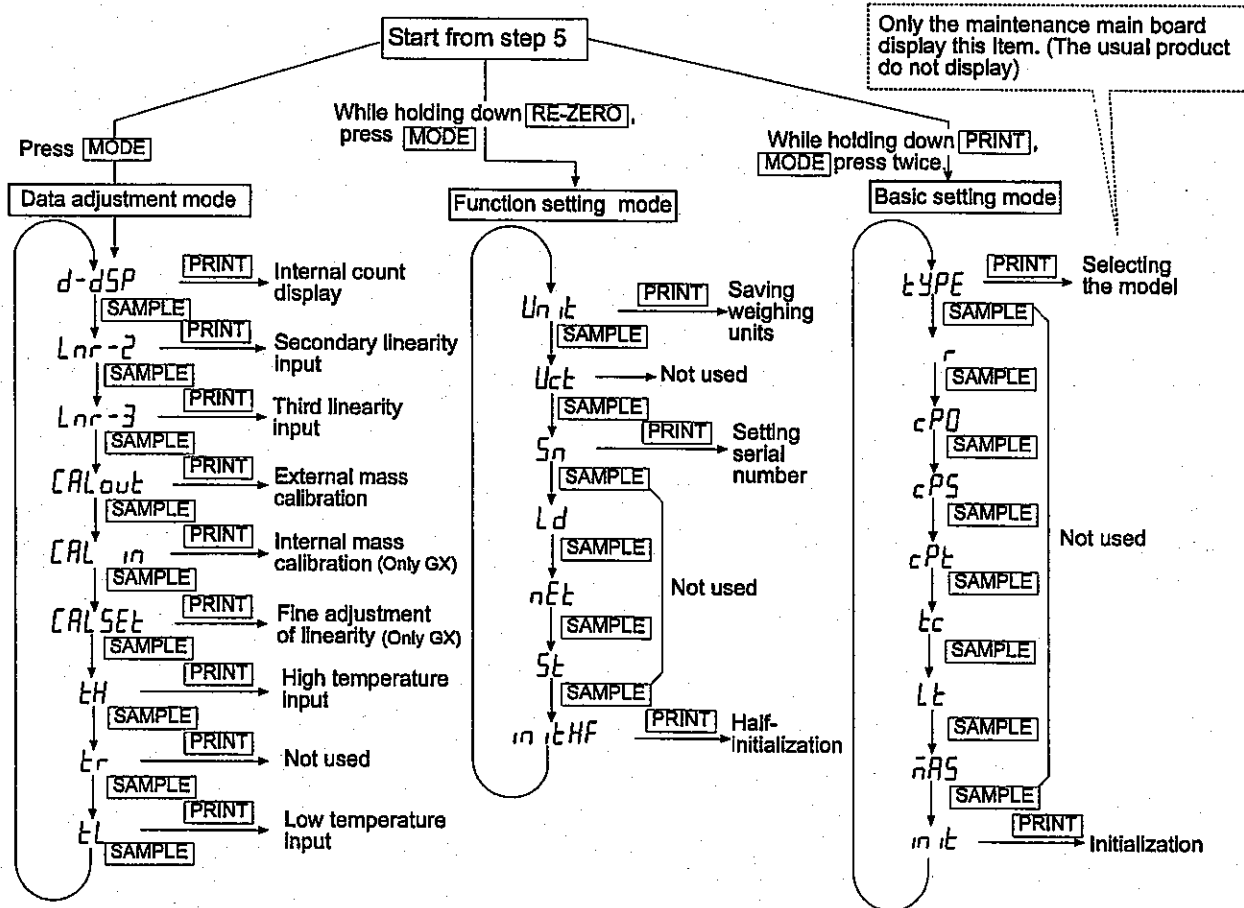

Note: In the above content, the way of displaying may differ depending on the each software version.

6.4 Check Mode Menus

Internal count display

While in the **d-dSP** display, press the **PRINT** key to display the internal count. Use the **SAMPLE** key to go to the next data.

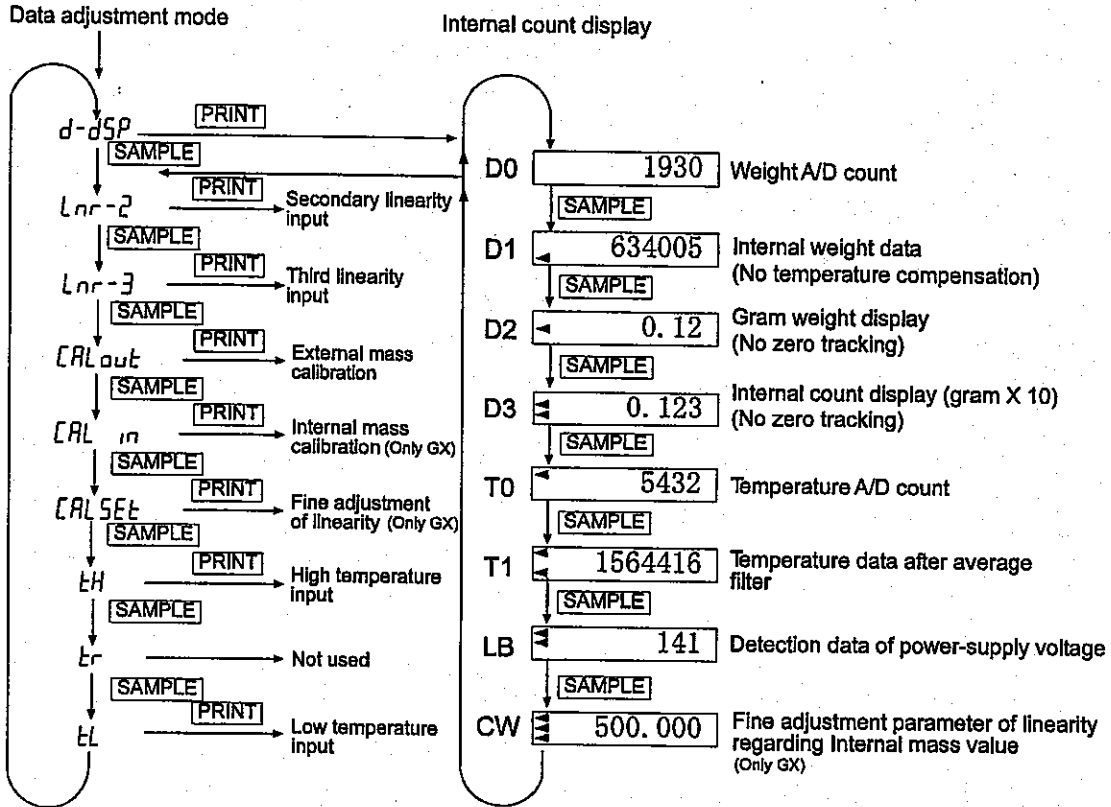

Only GX

- When the **PRINT** key is pressed in the display other than CW, the internal mass will be raised or lowered.
- When the **PRINT** key is pressed in the CW display, fine adjustment parameter of linearity regarding internal mass value will be changed. Use the following keys to change the value.

RE-ZERO key: increases the value by one
SAMPLE key: decreases the value by one
PRINT key: saves the final value
CAL key: cancels the value

• Digital offset

While in the D0, D1 display, or T0, T1 display, while holding down the **RE-ZERO** key and **MODE** key, the balance enters the digital offset input mode.

(In this input mode, the load sensor or the temperature sensor is disconnected internally. And certain electric signals are input in each A to D converter. Refer to "6-13 Method of identifying defect location")

6.5 Initialization

- <CAUTION>** • Do not proceed to this initialization if you can not prepare a room controlled with temperature. (Because it is necessary to adjust temperature data after this initialization)

Note that the following data is initialized by this operation.

- Temperature compensation data for each unit (Then some fixed data is input compulsorily)
- Linearity compensation data (The data is cleared), serial number, weighing units
- Internal parameter settings (Certain values are input compulsorily)

Initialization procedure

Follow the procedure below to completely initialize the data stored in the non-volatile memory.

- Step 1. See the check mode menu flowchart on page 26 to display basic setting mode `TYPE` or `Pr`.
- Step 2. Press the `SAMPLE` key several times. `int` will be displayed.
- Step 3. Press the `PRINT` key. `ALL na` will be displayed. To cancel the operation, press the `CAL` or `PRINT` key. The next item will be displayed.
- Step 4. Press the `RE-ZERO` key. `ALL Ga` will be displayed. To cancel the operation, press the `CAL` key. The next item will be displayed
- Step 5. Press the `PRINT` key. `< ALL Ga`, then `End` will be displayed. The next item will be displayed. Change the other items as necessary.
- Step 6. To quit the operation, press the `ON/OFF` key. The display will be turned OFF.

6.6 Model type Selection (Only for maintenance electric board)

Model type selection is available for the maintenance board only.

Model selection procedure

Follow the procedure below to select the balance model type.

Step 1. Verify the following item of the 7PZ:3470A/B/C/D/E/F (Main board for the maintenance).

Verify the type of the board

- To the each type (A/B/C/D/E/F), verify the value of R32/R33 and the jumper setting are correct. (Refer to the Technical information "4. Parts Layout of Circuit Diagrams")

For the main board unit, verify if it is adjusted completely

- Connect the AC adapter to the main board unit. If **Error 9** is displayed, the main board is not adjusted yet and it should be adjusted for a maintenance board.

Step 2. See the check mode menu flowchart on page 26 to display basic setting mode **TYPE**.

Step 3. Press the **PRINT** key. Confirm the type on the display as follows. (ex. **600 5%** ...7PZ:3470A)

Type of board	Model type which can be set	Type displayed initially
7PZ:3470A	GX-200/400/600	600 5%
7PZ:3470B	GX-2000/4000/6100	6100 5%
7PZ:3470C	GX-6000/8000	8000 5%
7PZ:3470D	GF-200/300	300 5F
7PZ:3470E	GF-1200/2000/3000	3000 5F
7PZ:3470F	GF-6000	6000 5F

Use the following keys to select the model type

RE-ZERO key: changes the model type. (Change the model type according to the kinds of PZ)

PRINT key: saves the final model type.

CAL key: cancels the data.

When the model after change is the same as that before change, the stabilization indicator illuminates.

Step 4. Press the **PRINT** key. **End** appears. Then, the next item appears.

6.7 Coarse Operation Check & Adjustment

1. A/D count check

The A/D count can be checked in the check mode.

Follow the procedure below to verify the A/D values for weight data (D0) and temperature data (T1).

Step 1. Display the data adjustment mode d-dSP after getting into check mode shown on page 26.

Step 2. Press the PRINT key to display XXXX . (D0 data, weight A/D count)

Step 3. Check that the pan and pan support receptor is installed properly. Verify that the count without load (zero point) is within 2000 – 4000 counts.

Note: If the zero point is not within the specification, adjust it by cutting jumpers (on the main board).

Cut JP2...Zero point +1500(D0), cut JP3...Zero point +3000(D0)

Step 4. Place the mass in the table below on the pan. Read the count with load. Subtract the count without load from the count with load to obtain the span value. Verify that the span value is within the range shown in the table below.

In the D0 data mode (Weight A/D count), press the SAMPLE key twice to display X.XX (D2 data). Verify that the dispersion is within the specifications as below when the mass is placed on the pan.

Model	Masses	Span (D0 data)	Dispersion (D2 data)
GX-200/400/600 GF-200/300	500g	6500~8400	MAX-MIN: 0.002g/5 seconds
GX-2000/4000/6100 GF-1200/2000/3000	5kg	6300~8910	MAX-MIN: 0.02g/5 seconds
GX-6000/8000 GF-6000	5kg	3000~4000	MAX-MIN: 0.2g/5 seconds

Step 5. In the D2 data mode, press the SAMPLE key three times to display XXXXXX . (T1 data)

Step 6. Verify that the count at room temperature (15-25°C) is within the range shown in the table below.

Model	Absolute value (T1 data)	Dispersion (T1 data)
GX-200/400/600 GF-200/300	1500000-1700000	MAX-MIN: 20 counts/5 seconds
GX-2000/4000/6100 GF-1200/2000/3000		
GX-6000/8000		
GF-6000		

2. Motor operation check (Only GX)

Step 1. In the D0 data mode (weight A/D count), press the **SAMPLE** key twice.
X.XXX will be displayed. (D2 data)

Step 2. Each time the **PRINT** key is pressed, the motor rotates and **MO** is displayed. Verify the following:

Applying and releasing the internal mass is performed smoothly.
 No strange noises are generated during the movement of the internal mass.

Step 3. In the D2 data mode, press the **PRINT** key five times, and check the repeatability of internal mass.

Model	Repeatability specifications (D2 data mode)
GX-200/400/600	± 0.002 g
GX-2000/4000/61000	± 0.02 g
GX-6000/8000	± 0.2 g

3. Insulation check of force coil

By using a multimeter which can measure $20\text{M}\Omega$ or more, measure the resistance between the force coil (pin 1 or pin 2 of J3) and the frame.

Verify that the measurement result is the same as when the terminal of multimeter is opened.

6.8 Coarse Adjustment

1. Calibration

GX model (Internal mass calibration)

With nothing placed on the pan, warm up the balance for at least half an hour. Calibration is performed in the check mode **[CAL in]** display.

Follow the procedure below to calibrate.

- Step 1. Display the data adjustment mode **[d-dSP]** after getting into check mode shown on page 26.
- Step 2. Press the **[SAMPLE]** key several times. **[CAL in]** is displayed.
- Step 3. Press the **[PRINT]** key. The motor starts to operate.
- Step 4. The display changes in turn as follows:

[CAL.] → **<CAL .** → **[CAL .]** → **<CAL .** → **End**

- Step 5. The operation is completed. Proceed to the next step.

GF model (External mass calibration)

With nothing placed on the pan, warm up the balance for at least half an hour. Calibration is performed in the check mode **[CALout]** display.

Follow the procedure below to calibrate.

- Step 1. Display the data adjustment mode **[d-dSP]** after getting into check mode shown on page 26.
- Step 2. Press the **[SAMPLE]** key three times. **[CALout]** is displayed.
- Step 3. Press the **[PRINT]** key.
- Step 4. **[CAL 0]** is displayed. Check the standard mass for calibration in table below.

Model	Standard mass	Model	Standard mass
GF-200	200g	GF-2000	2kg
GF-300	200g	GF-3000	2kg
GF-1200	1kg	GF-6000	5kg

- Step 5. With nothing placed on the pan, press the **[PRINT]** key. **<CAL 0** is displayed.
- Step 6. After it stabilized, 200 is displayed. (Example of the GF-200)
- Step 7. Place the calibration mass specified in step 4 on the pan. Press the **[PRINT]** key. **<200** is displayed (Example of the GF-300)
- Step 8. After it stabilized, **End** is displayed.
- Step 9. Remove the mass.

2. Corner load adjustment

Corner load is adjusted in the check mode D2 display.

For the adjustment method, shave the adjustment hole (three places) of the roberval (upper-back, thin part) using a file.

(By the corner load adjustment, particles are likely to be generated. Be careful that the particles do not affect the force motor unit or the circuit board. Remove the particles by using adhesive tape.)

Coarse adjustment

- Step 1. Display the data adjustment mode $d-d5P$ after getting into check mode shown on page 26.
- Step 2. Press the **PRINT** key to display $XXXX$. (D0 data-weight A/D count)
- Step 3. In the D0 data mode (weight A/D count), press the **SAMPLE** key twice to display $X.XXX$. (D2 data as gram weight display).
- Step 4. In the D2 data mode, place an external mass as shown on the table below on the center of the pan and at four positions half the distance from the center of the pan to the edge. See the figure on next page.
Adjust the corner load error at the back of weighing pan to be within about +10digits, shaving the center hole of the corner load adjustment holes of the rolerval with a shaft of drill $\phi 3$. Turn the shaft of the drill gently by hand.
In the initial state, If the corner load error at the back of weighing pan is minus counts, shave the bottom side of thin part at a level using a file.
- Step 5. Adjust to be within the about +5digits as the specifications, by shaving the corner load adjustment hole of the plus side (right or left) on the weighing pan.
When adjusting the corner load by shaving, a drift of the zero point may be generated. After shaving, load the mass listed in table below on the front, back, left and right of the weighing pan, and work again after the drift of the center zero point is confirmed to be within ± 3 digits.

Note: In case of shaving large amounts using a file, note the zero point drift.

Model	Masses	Difference with center (front-back)	Difference with center (right-left)	Drift value of zero point
GX-200/400/600 GF-200/300	300g	± 0.010 g	± 0.005 g	± 0.003 g
GX-2000/4000/6100 GF-1200/2000/3000	3kg	± 0.10 g	± 0.05 g	± 0.03 g
GX-6000/8000 GF-6000	3kg	± 1.0 g	± 0.5 g	± 0.3 g

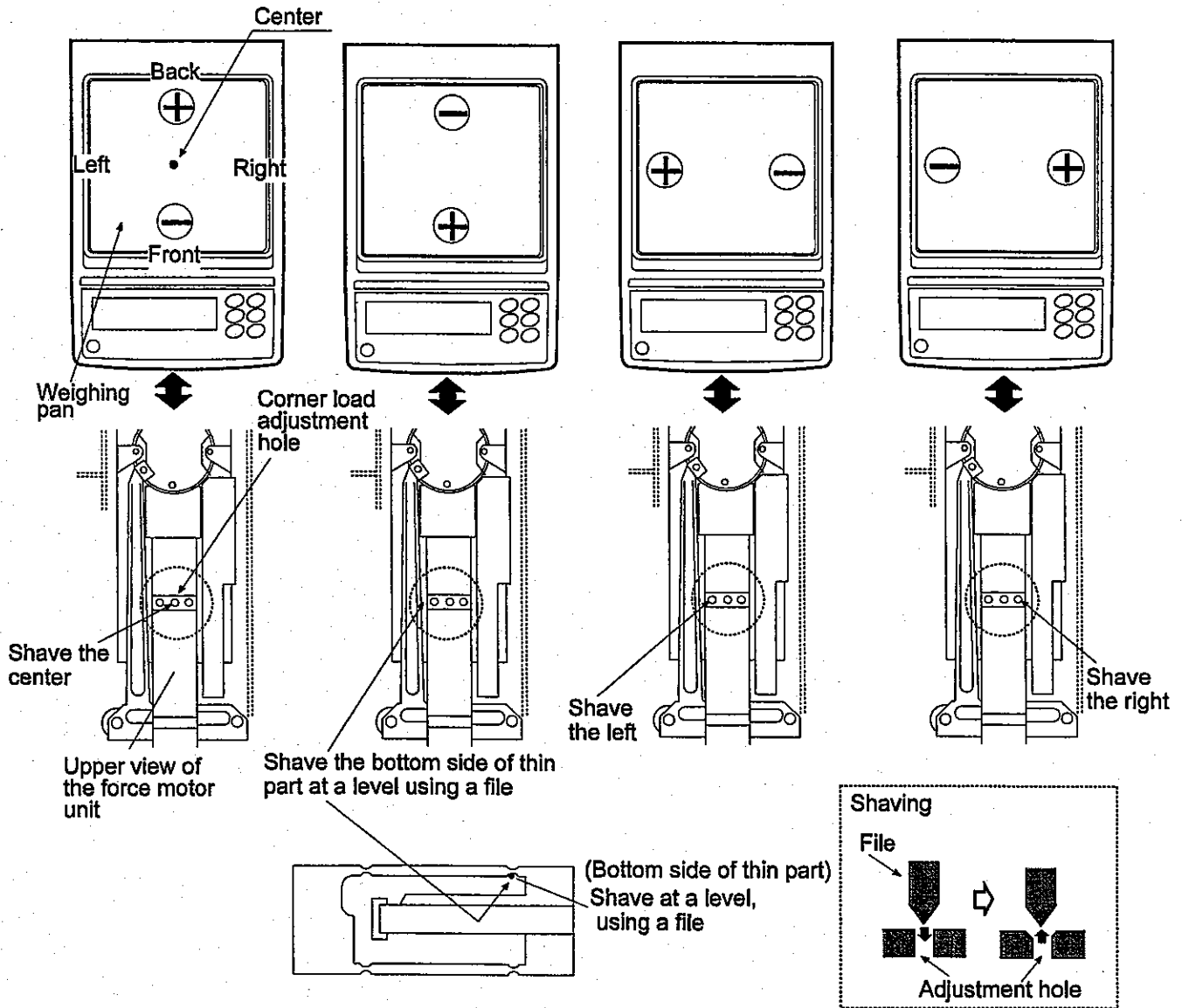

6.9 Temperature Adjustment

A room or chamber that can be set at 10°C and 30°C is required for this adjustment. The balance must stabilize at each temperature for more than 4 hours before the data is taken.

Input high temperature data initially, then input low temperature data. Finally go back to high temperature state, and check the zero drift and the span drift.

Use the same mass when inputting data for both high temperature and low temperature.

1. Inputting the temperature data

- Step 1. Display the data adjustment mode after getting into check mode shown on page 26.
- Step 2. Press the key six times. appears. Press the key two more times. Then appears. Input high temperature data in the *tH* display, low temperature data in the *tL* display.
- Step 3. In the or display, press the key. The motor starts and adjusts the internal mass position correctly. Then or is displayed respectively.
- Step 4. With nothing placed on the weighing pan, press the key as zero point data. To cancel the operation, press the key.
- Step 5. After it stabilized, or is displayed respectively.
- Step 6. Place the mass in table below on the weighing pan and press the key.

Model		Masses
GX-200/400/600	GF-200/300	400 g
GX-2000/4000/61000	GF-1200/2000/3000	2 kg
GX-6000/8000	GF-6000	5 kg

(In case of GX200/400/600 model, if the key is pressed without placing any mass on the pan, load will be applied using the internal mass instead of external mass 400g.)

- Step 7. After it stabilized, is displayed.
- Step 8. Remove the mass and proceed to the next step.

2. Temperature adjustment check

- Step 1. After inputting the low temperature data, keep the temperature and select D2 data mode in the internal count display.
- Step 2. Press the **RE-ZERO** key to show zero. Note the zero point reading. Place a mass in table below on the pan and note the span reading. The span data is calculated after subtracting the zero point reading from the full point reading. Remove the mass. (In case of GX200/400/600, the internal mass can be used. Press the **PRINT** key to raise or lower the internal mass.)
- Step 3. Set the temperature to 30°C again. Leave the balance at that temperature for at least 4 hours. (Leave the balance with D2 data mode.)
- Step 4. Note the zero point reading.
- Step 5. Press the **RE-ZERO** key to display zero.
- Step 6. Place a mass in table below on the pan and note the span reading. The span data is calculated after subtracting the zero point reading from the full point reading. (In case of GX200/400/600, the internal mass can be used. Press the **PRINT** key to raise or lower the internal mass.)
- Step 7. Verify that the changes in the zero point and span are within the specifications.

Model	Masses	Zero (D2 data mode)	Span (D2 data mode)
GX-200/400/600 GF-200/300	400g	±0.020 g	±0.016 g
GX-2000/4000/61000 GF-1200/2000/3000	2kg	±0.20 g	±0.08 g
GX-6000/8000 GF-6000	5kg	±2.0g	±0.5 g

6.10 Fine Adjustment

1. Corner load adjustment

In the D2 data mode, place an external mass on the center of the pan and at four positions half the distance from the center of the pan to the corner edge shown in a figure below. Verify that the difference between the values at the center and at each position is within the specifications.

About the adjustment method, refer to the "2. Corner load adjustment" of "6.8 Coarse Adjustment".

When adjusting the corner load error by shaving, zero point drift may be generated. After shaving, load the mass listed in table below on the front, back, left and right of the weighing pan, and work after the drift of the center zero point is confirmed to be within the ± 2 digits.

Model		Masses	Difference with center (D2 data mode)	Drift value (D2 data mode)
GX-200	GF-200	100g	$\pm 0.003g$	$\pm 0.002g$
	GF-300	200g	$\pm 0.003g$	$\pm 0.002g$
GX-400		200g	$\pm 0.003g$	$\pm 0.002g$
GX-600		300g	$\pm 0.003g$	$\pm 0.02g$
	GF-1200	1kg	$\pm 0.02g$	$\pm 0.02g$
GX-2000	GF-2000	1kg	$\pm 0.02g$	$\pm 0.02g$
	GF-3000	2kg	$\pm 0.03g$	$\pm 0.02g$
GX-4000		2kg	$\pm 0.03g$	$\pm 0.02g$
GX-6100		3kg	$\pm 0.04g$	$\pm 0.02g$
GX-6000	GF-6000	4kg	$\pm 0.2g$	$\pm 0.2g$
GX-8000		4kg	$\pm 0.1g$	$\pm 0.2g$

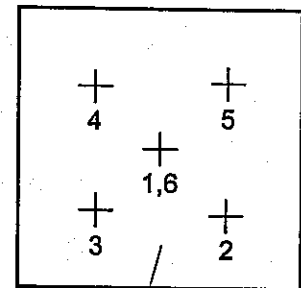

Weighing pan

2. Linearity adjustment (Lnr-2, 3) / Linearity and Hysteresis check

Before adjusting linearity, warm up the balance for at least one hour. Apply a preliminary load by placing and removing a load with the same weight value as the full scale value. Perform this pre-load three times. Follow the procedure below to input linearity data.

Note: Be careful, the corner load error has a bad effect on the linearity adjustment or linearity and hysteresis check. (Regarding the mass used below, cylindrical shape mass is suitable because corner load error get minimized)

Step 1. Display the data adjustment mode $d-d5P$ after getting into check mode shown on page 26.

Step 2. In case of GX200/400/600/2000/4000, GF-200/300/1200/2000/3000

Press the **SAMPLE** key one time. $Lnr 2$ is displayed.

In case of GX6100/6000/8000, GF-6000

Press the **SAMPLE** key two times. $Lnr 3$ is displayed.

- Step 3. Press the **PRINT** key. The motor starts and adjusts the internal mass position correctly. Then **Lnr 0** is displayed. (Press the **CAL** key to cancel this procedure.)
- Step 4. With nothing placed on the pan, press the **PRINT** key.
- Step 5. After stabilization, **Lnr 1** is displayed (Press the **CAL** key to cancel the operation.)
- Step 6. Place mass A shown on the table below on the weighing pan and press the **PRINT** key.
- Step 7. After it stabilized, **Lnr 2** is displayed. (Press the **CAL** key to cancel the operation.)
- Step 8. Remove mass A, place mass B and press the **PRINT** key.
- Step 9. After it stabilized, **Lnr 3** is displayed. (Press the **CAL** key to cancel the operation.)
- Step 10. Add mass A (confirm to place mass B and mass A on the weighing pan) and press the **PRINT** key.
In case of GX200/400/600/2000/4000 and GF-200/300/1200/2000/3000, go to the Step 15.
In case of GX6100/6000/8000 and GF-6000, go to the Step 11, and input the Lnr-4 and Lnr-5 data.
- Step 11. After it stabilized, **Lnr 4** is displayed. (Press the **CAL** key to cancel the operation.)
- Step 12. Remove all mass on the weighing pan, Place mass C and press the **PRINT** key.
- Step 13. After it stabilized, **Lnr 5** is displayed. (Press the **CAL** key to cancel the operation.)
- Step 14. Add mass A (confirm to place mass C and mass A on the weighing pan) and press the **PRINT** key.
- Step 15. After it stabilized, **End** is displayed.

Step 16. The linearity adjustment is completed. Remove the mass from the pan.

Model		Input grade	Weights			Input method and actual load on the pan					
						Lnr0	Lnr1	Lnr2	Lnr3	Lnr4	Lnr5
			A	B	C	No load	A	B	A+B	C	G+A
GX-200	GF-200	Secondary	100g	100g	—	0	100g	100g	200g	—	—
	GF-300	Secondary	100g	200g	—	0	100g	200g	300g		
GX-400		Secondary	200g	200g	—	0	200g	200g	400g	—	—
GX-600		Secondary	300g	300g	—	0	300g	300g	600g	—	—
	GF-1200	Secondary	500g	500g	—	0	500g	500g	1kg		
GX-2000	GF-2000	Secondary	1kg	1kg	—	0	1kg	1kg	2kg	—	—
	GF-3000	Secondary	1kg	2kg	—	0	1kg	2kg	3kg		
GX-4000		Secondary	2kg	2kg	—	0	2kg	2kg	4kg	—	—
GX-6100		Third	2kg	2kg	4kg	0	2kg	2kg	4kg	4kg	6kg
GX-6000	GF-6000	Third	2kg	2kg	4kg	0	2kg	2kg	4kg	4kg	6kg
GX-8000		Third	4kg	2kg	4kg	0	4kg	2kg	6kg	4kg	8kg

Linearity and Hysteresis check

Calibrate by using the calibration mass in table below.

After calibration, in the D2 data mode, place the specified check mass in the table below one by one on the pan, and check that the difference between the true value and the displayed value is within the specifications (linearity). After reaching the weighing capacity, remove each mass one by one, and check that the difference between increasing points and decreasing points are within the specifications (hysteresis).

Model		Calibration masses	Check masses	Linearity (D2 mode)	Hysteresis (D2 mode)
GX-200	GF-200	200g	100g×2	±0.002g	±0.002g
	GF-300	300g	100g×3	±0.002g	±0.002g
GX-400		400g	100g×4	±0.002g	±0.002g
GX-600		600g	200g×3	±0.003g	±0.003g
	GF-1200	1kg	500g×2	±0.02g	±0.02g
GX-2000	GF-2000	2kg	1kg×2	±0.02g	±0.02g
	GF-3000	3kg	1kg×3	±0.02g	±0.02g
GX-4000		4kg	1kg×4	±0.02g	±0.02g
GX-6100		6kg	2kg×3	±0.03g	±0.03g
GX-6000	GF-6000	6kg	2kg×3	±0.1g	±0.2g
GX-8000		8kg	2kg×4	±0.1g	±0.2g

3. Fine adjustment of linearity (CAL SET) [Only GX]

The following explains about how the linearity around the internal mass is adjusted precisely.

(1) Warm up and preliminary load

Warm up the balance for at least one hour.

Apply a preliminary load by placing a load with the full scale value and remove it. Perform this pre-load three times.

(2) External mass calibration (CAL out)

Step 1. Display the data adjustment mode d-dSP after getting into check mode shown on page 26.

Step 2. Press the SAMPLE key three times. CALout is displayed.

Step 3. Press the PRINT key. The motor starts and adjust the internal mass position correctly.

Step 4. CAL 0 is displayed. Check the standard mass for calibration in table below.

Model	Standard masses
GX-200	200g
GX-400	400g
GX-600	500g
GX-2000	2kg
GX-4000	4kg
GX-6100	5kg
GX-6000	5kg
GX-8000	5kg

To change the calibration mass value, press the SAMPLE key and change the value as necessary using the following keys.

SAMPLE key: changes the blinking digit position.

RE-ZERO key: changes the value of the blinking digit.

PRINT key: saves the data.

Step 5. With nothing placed on the pan, press the PRINT key. <CAL 0 is displayed.

Step 6. After it stabilized, 500 is displayed. (Example of the GX-600)

Step 7. Place the calibration mass specified in step 4 on the pan. Press the PRINT key. < 500 is displayed. (Example of the GX-600)

Step 8. After it stabilized, End is displayed.

Step 9. Remove the mass.

(3) Fine adjustment of linearity

- Step 1. In the data adjustment mode $d-dSP$, press the **SAMPLE** key five times. **CALEE** is displayed.
- Step 2. Press the **PRINT** key. The motor starts and adjusts the internal mass position correctly.
- Step 3. The display changes in turn as follows:
EE → **<EE .** → **EE .** → **<EE .** → **End** → **EH**
- Step 4. Proceed to the next step.

(4) Internal mass calibration (CAL in)

- Step 1. In the data adjustment mode $d-dSP$, press the **SAMPLE** key four times. **CAL in** is displayed.
- Step 2. Press the **PRINT** key. The motor starts and adjusts the internal mass position correctly.
- Step 3. The display changes in turn as follows:
CAL → **<CAL .** → **CAL .** → **<CAL .** → **End**
- Step 4. Proceed to the next step.

(5) In D2 data mode, verify the error of the fine adjustment of linearity

- Step 1. In the data adjustment mode $d-dSP$, press the **PRINT** key. **XXXX** is displayed. (D0 data-weight A/D count)
- Step 2. Press the **SAMPLE** key twice. **XXXX.X** is displayed. (D2 data-gram weight display)
- Step 3. Place again the calibration mass used in "(2) External mass calibration". Verify that the error (the difference between the displayed weight value and the mass value) is within the specifications.

If not within the specifications, perform the fine adjustment of linearity again (operation of (2), (3)), or perform the digital correction as explained later.

Model	Standard masses	Specifications (D2 data mode)
GX-200	200g	±0.002g
GX-400	400g	
GX-600	500g	
GX-2000	2kg	±0.04g
GX-4000	4kg	
GX-6100	5kg	
GX-6000	5kg	±0.2g
GX-8000	5kg	

- (6) Calibrate using the internal mass and verify the fine adjustment of linearity error (operation (4)-(5)). Perform this three times, verify that the all data be within the specifications.

Digital correction of the fine adjustment of linearity

If the linearity error is not within the specifications, it can be corrected digitally. After correcting the value digitally, calibrate again using the internal mass and verify the error.

- Step 1. In the data adjustment mode $d-dSP$, press the **PRINT** key. **XXXX** is displayed. (D0 data-weight A/D count)
- Step 2. Press the **SAMPLE** key seven times. **XXX.XXX** is displayed. (CW display-fine adjustment parameter of linearity regarding internal mass)
- Step 3. To change the internal mass value, press the **PRINT** key and change the value as necessary using the following keys.
- | | |
|---------------------|-----------------------------|
| RE-ZERO key: | increases the value by one. |
| SAMPLE key : | decreases the value by one. |
| PRINT key: | saves the final data. |
| CAL key: | cancels the data. |
- Step 4. Press the **PRINT** key. Then, the balance returns to the CW display with corrected data.

6.11 Parameter Settings

1. Unit setting

The weighing units can be saved in the check mode. Follow the procedure below to save the units.

- Step 1. Display the function setting mode Unit, after getting into check mode shown on page 26.
- Step 2. Press the PRINT key. Unit g is displayed.
- Step 3. Save the units using the following keys if it is needed.
 - RE-ZERO key: selects the displayed unit.
 - SAMPLE key: changes the unit to be displayed.
 - CAL key: cancels the operation.
- Step 4. When every units you need are saved, press the PRINT key.
- Step 5. End is displayed to indicate that the operation is completed.

2. Serial number setting

Follow the procedure below to set the serial number.

- Step 1. Display the function setting mode Unit, after getting into check mode shown on page 26.
- Step 2. Press the SAMPLE key. Sn is displayed.
- Step 3. Press the PRINT key. Then the display starts to blink.
- Step 4. Using the following keys, input the serial number on the label attached to the each balances.
 - RE-ZERO key: changes the value of the blinking digit.
 - SAMPLE key: changes the blinking digit position.
 - CAL key: cancels the operation
- Step 5. When the serial number is set, press the PRINT key.
- Step 6. End is displayed to indicate that the operation is completed.

6.12 Half-initialization

Half-initialization changes all the user settings(*1) to the default values. Follow the procedure below.

- Step 1. Display the function setting mode `Unit`, after getting into check mode shown on page 26.
- Step 2. Press the `SAMPLE` key several times. `in iLHF` is displayed.
- Step 3. Press the `PRINT` key. `HF no` is displayed. (To cancel the operation, press the `CAL` key or `PRINT` key.)
- Step 4. Press the `RE-ZERO` key. `HF G0` is displayed. (To cancel the operation, press the `CAL` key.)
- Step 5. Press the `PRINT` key. `<HF G0` and then `End` is displayed. The Half-initialization is completed.

(*1) The user settings

- Function setting
- Value of the external mass for calibration
- Content of data memory function
- Density data of liquid for density measurement

6.13 Method of identifying defect location (Electrical part or Mechanical part)

In this chapter it explains about how easily you can check the cause of malfunction in the mechanical parts or in the electrical part, without disassembling the balance. It is advantageous if the defect is "unstable data" or "repeatability error".

1. Simple method (Self Check Function)

Self-checks the balance performance using the internal mass.

If the balance displays **[CH na]** after this operation, the electrical part (especially AMZ51) is clearly defective. It is necessary to check or replace the AMZ51.

Step 1. Press and hold the **[MODE]** key until **[RESPONSE]** is displayed.

The balance automatically starts to check the balance performance and sets the response feature.

Do not allow vibration or drafts to affect the balance during this adjustment.

Step 2. After automatic adjustment, the balance displays the updated response indicator and returns to the weighing mode. The response indicator remains displayed for a while.

(GX model). "**[MID]** **[OK]**" (GF model) "**[OK]**"

The example above indicates that the result of the self check is good and **[MID]** is selected as the response rate.

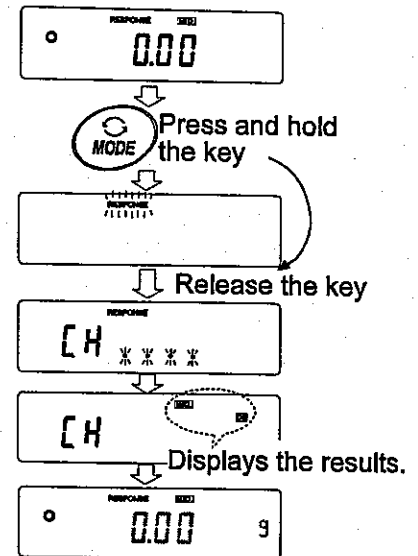

2. Method of identifying in the internal offset mode

* If both i) and ii) below are OK, the electrical part is not defective. In this case, it is likely that the cause is in the mechanical part.

* If both of i) and ii) are NG, or one of two is NG, the electrical part is defective. It is necessary to check or replace the electrical part especially AMZ51.

i) Operation confirmation for the electrical portion of the weight A/D part by itself

Step 1. Display the data adjustment mode **[d-dSP]** after getting into check mode shown on page 26.

Step 2. Press the **[PRINT]** key. **[XXXX]** is displayed. (D0 data mode-weight A/D count)

Step 3. Press and hold **[RE-ZERO]** key and press **[MODE]** key. "- 1-" is displayed on the upper left display in offset mode (seven segments). See the example on next page. With a same key operation, the mode can be moved to "- 2-", "- 3-" and "- 4-".

(1) Verify that the offset 1 (- 1-) shows within 2940-3060.

(2) In the offset 2 (- 2-), verify that the data is within 4400-4600.

(3) In the offset 3 (- 3-), verify that the data is within 5900-6100.

(4) In the offset 4 (- 4-), verify that the data is within 7350-7650.

Step 4. Press the **[SAMPLE]** key. **[XXXXXX]** is displayed. (D1 display-Internal weight data)

Step 5. Press and hold **RE-ZERO** key and press **MODE** key. "- 1-" is displayed on the upper left display in offset mode (seven segments). See the example. With a same key operation, the mode can be moved to "- 2-", "- 3-" and "- 4-".

(1) In the offset 3 (- 3-), verify that the data is within 2020000-1930000, and the data of dispersion is within 3 counts (MAX-MIN) in 5 seconds.

Offset mode (Weight A/D)

Weight A/D input	Seven segments on the upper left	D0 data	D1 data
Offset 1 only	- 1-	Approx.3000	Approx.1000000
Offset 2 only	- 2-	Approx.4500	Approx.1500000
Offset 3 only	- 3-	Approx.6000	Approx.2000000
Offset 4 only	- 4-	Approx.7500	Approx.2500000
Offset 5 only	- 5-	Approx.7500	Approx.2500000
Offset 6 only	- 6-	Approx.12000	Approx.4000000
Ordinary state (Connecting to the mechanical part)	No display	Weight A/D count	Internal weight data D1

Example) In the D0 data mode, to display "- 1-".

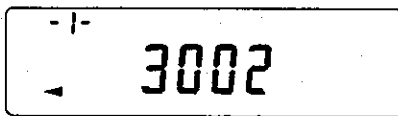

ii) Operation confirmation for the electrical portion of the temperature A/D part by itself

Step 1. In the D1 data mode, press the **SAMPLE** key four times. **XXXXXX** is displayed. (T1 data mode-Temperature A/D count after average filter)

Step 2. Press and hold **RE-ZERO** key and press **MODE** key. "- 1-" is displayed on the upper left display in offset mode (seven segments).

(1) In the offset 1 (- 1-), verify that the data is within 170000-210000, and the data of dispersion is within 10 counts (MAX-MIN) in 5 seconds.

Offset mode (Temperature A/D)

Temperature A/D input	Seven segments on the upper left	T0 data	T1 data
Offset 1 only	- 1-	Approx.670	Approx.200000
Ordinary state (Connecting to the temperature sensor)	No display	Temperature A/D count	Temperature data T1 after average filter

Appendix B

GF Technical Information

[Blank Page]

Contents

- 1. Introduction 4
 - 1.1 The Compositions of Products 4
 - 1.2 Block Diagram of the Circuit..... 5

- 2. Exploded Views and Parts Lists 6
 - 2.1 Sensor Unit 6
 - Exploded view 6
 - Parts List 7
 - 2.2 Lower Case 10
 - Exploded view 10
 - Parts List 11
 - 2.3 Upper Case 12
 - Exploded view 12
 - Installing the weighing pan unit 13
 - Parts List 13

- 3. Circuit Diagram and Parts List..... 15
 - Circuit Diagram, 7PZ-3470D/E/F, 7PZ-3471, 7PZ-3472, 7PZ-3474, 7PZ-3475 15
 - Circuit Diagram, PZ-3586 (Comparator) Circuit Diagram, 7PZ-3601 (GX-06 Analog Output) 16
 - Parts List of 7PZ-3470D/E/F 17
 - Parts List of 7PZ-3471 19
 - Parts List of 7PZ-3472 19
 - Parts List of 7PZ-3474 20
 - Parts List of 7PZ-3475 20
 - Parts List of 7PZ-3586 (GX/GF-04 Comparator Output) 20
 - Parts List of 7PZ-3601 (GX/GF-06 Analog Output) 21

- 4. Parts Layout of Circuit Diagrams 22
 - Main Board: 7PZ-3470D, 7PZ-3470E, 7PZ-3470F 22
 - RS-232C Board: 7PZ-3471 Position Sensor Board: 7PZ-3472 23
 - Switch Board: 7PZ-3474 Relay Board: 7PZ-3475 23
 - GX/GF-04 Comparator output: 7PZ-3586 24
 - GX/GF-06 Analog output: 7 PZ-3601 24

1. Introduction

1.1 The Compositions of Products

This manual describes each composition of the mechanical units, electronic units and software for the GF serieses. These serieses contain the same units of parts as the following table.

Model	Circuit board				
	Main board	RS-232C board	Position sensor board	Switch board	Relay board
GF-200 GF-300	7PZ-3470D	7PZ-3471	7PZ-3472	7PZ-3474	7PZ-3475
GF-1200 GF-2000 GF-3000	7PZ-3470E				
GF-6000	7PZ-3470F				

The drawing No. of all circuits is QD-EC3-000655

Model	Mechanical unit	Reference
GF-200 GF-300	Sensor unit: {2.1 Sensor unit} Lower case unit: {2.2 Lower case} Upper case unit: {2.3 Upper case}	These GF balances (GF-200 GF-300) are used the sensor unit of the Roberval 600.
GF-1200 GF-2000 GF-3000		These GF balances (GF-1200, GF-2000,GF-3000) are used the sensor unit of the roberval 6000.
GF-6000		The GF balances (GF-6000) are used the sensor unit of the roberval 8000.

Refer to each parts list concerning different units and parts.

Model	Software version	Reference
GF-200 GF-300 GF-1200 GF-2000 GF-3000 GF-6000	Version 1.40 or later version	This software is common to all GF models.

Block Diagram of the Circuit

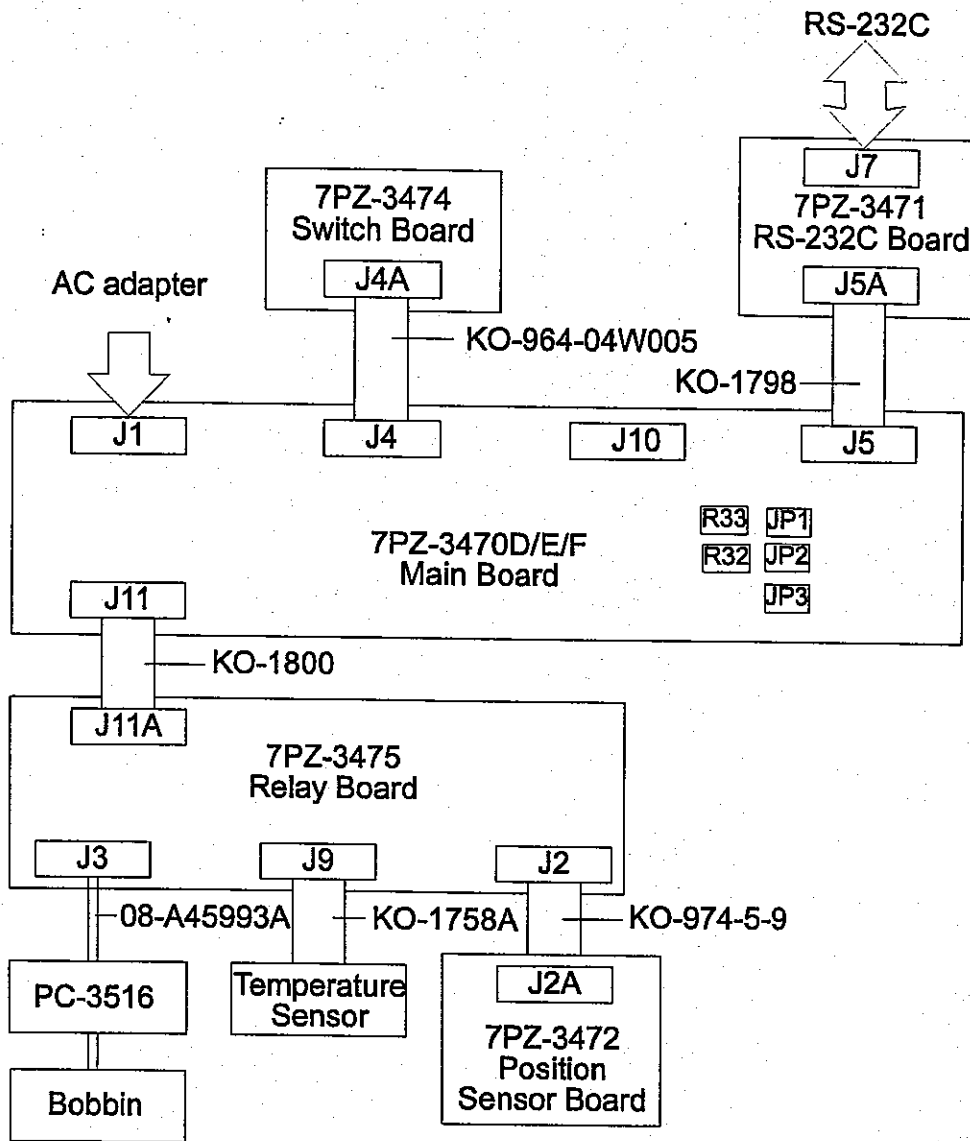

Deference of the main board (7PZ-3470D/E/F)

Type	Name	R32	R33	JP1	JP2	JP3
GF-200/ 300	7PZ-3470D	84Ω	84Ω	Open	Short	Open
GF-1200/ 2000/ 3000	7PZ-3470E	45Ω	45Ω	Open	Short	Open
GF-6000	7PZ-3470F	10Ω	-	Open	Open	Short

Cables

Cable No.	Name	QTY
KO-964-04W005	Switch board cable	1
KO-974-5-9	Position sensor cable	1
KO-1798	Serial interface cable	1
KO-1800	Relay board cable	1
KO-1758A	Temperature sensor cable	1
08-A45993A	Wire	2
KO-3516	F.P.C (GX)	1

2. Exploded Views and Parts Lists

2.1 Sensor Unit

Exploded view

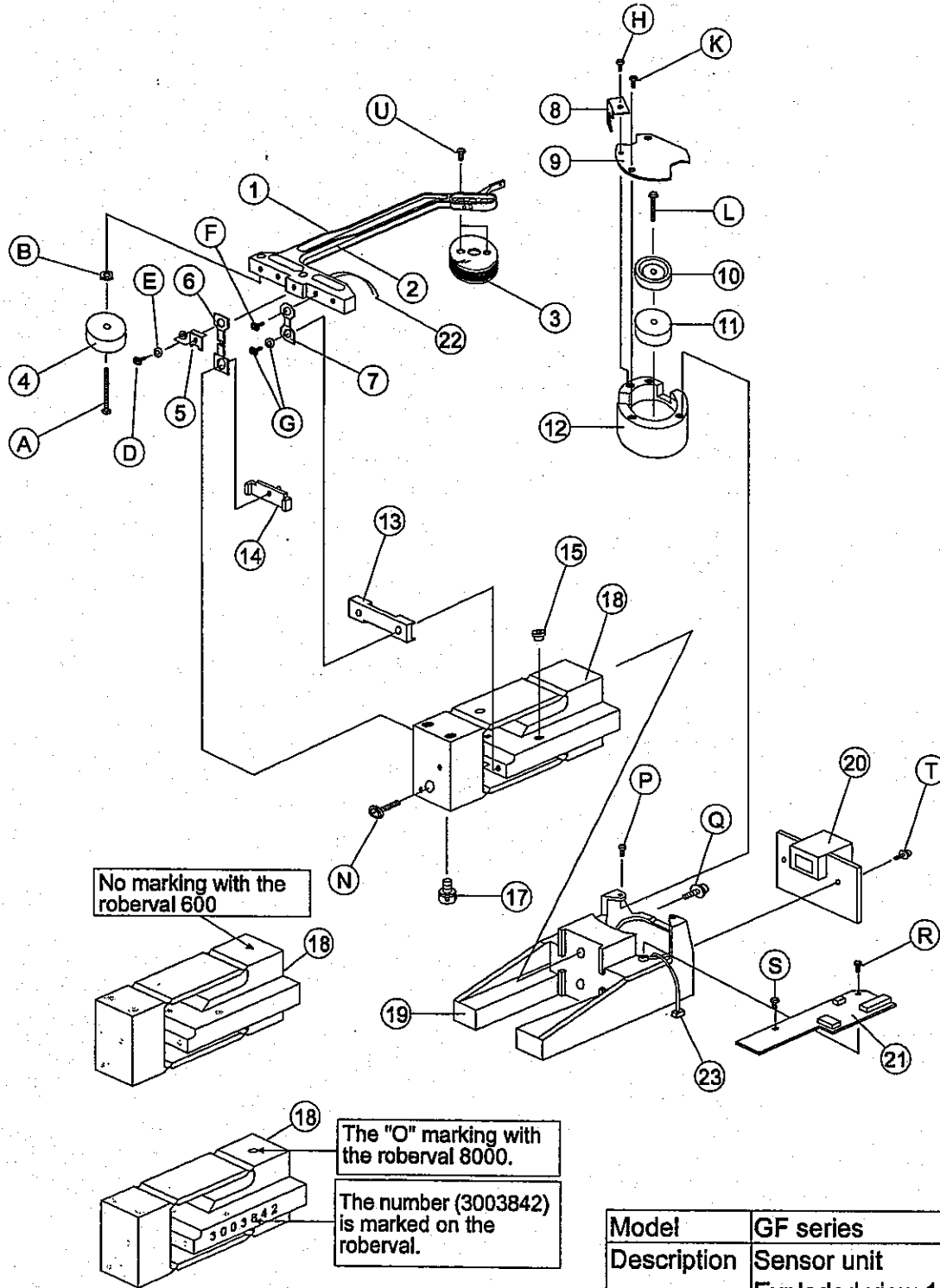

No marking with the roberval 600

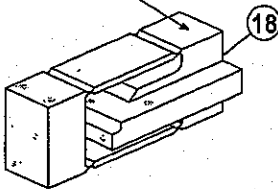

The "O" marking with the roberval 8000.

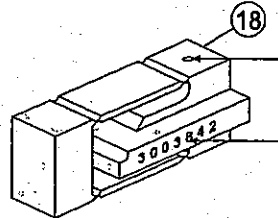

The number (3003842) is marked on the roberval.

Model	GF series
Description	Sensor unit Exploded view 1
Stock No.	
Drawing No.	

Parts List

No.	Part Name	Part No.	Qty
1	Beam 600	03-3003595C	1
	Beam 6000	03-3003594C	1
2	Flexible print circuit	PC-3516	1
3	Bobbin	09-4008009	1
4	Trimming mass, GF-200/ 300	05-4004892A	1
	Trimming mass, GF-1200/ 2000/ 3000/ 6000	05-4008821	1
5	Tension flexture holder 1, square bracket	04-B47107A	1
	Tension flexture holder 2, Φ 10.5 mm	05-4008826	1
6	Tension flexture for Roberval 600/6000	04-4008310	1
7	Fulcrum flexture for Roberval 6000	04-4008825	2
	Fulcrum flexture for Roberval 600	04-4008313	2
8	Beam stopper	04-4007990	1
9	Shield plate	04-4007989	1
10	Pole piece	05-4007994	1
11	Magnet	00-4007995	1
12	Yoke	05-4007993	1
13	Attachment, GF-200/ 300	03-4007970A	1
	Attachment, GF-1200/ 2000/ 3000/ 6000	03-4008768	1
14	Tension flexture holder 2	03-4007971A	1
15	Board spacer	05-4007992	1
17	Under hook	05-B43355	1
18	Roberval 600	05-3003841	1
	Roberval (cast) 8000	03-3003842	1
19	Main mechanical frame	03-2000468A	1
20	Position sensor board	7PZ-3472	1
21	Relay board	7PZ-3475	1
22	Wire	08-4008510	2
23	Temp. sensor cable fixed to yoke	KO-1758A	1

No.	Position	Part Name	Qty
A	Trimming mass	Pan head screw M3x30	1
B		Nut M3	1
D	Tension flexture	Pan/ Truss head screw M4x8	1
E		Coned disk washer M4	1
F	Fulcrum flexture	Pan head screw with toothed washer M4x10	2
G		Pan head screw with distance ring and coned disk washer M4x10	2
H	Beam stopper	Pan head screw with spring and plain washer M3x6	1
K	Shield plate	Pan head screw with spring and plain washer M3x6	2
L	Magnet	Pan head screw with spring washer M4x16, brass, no-plating	1
N	Tension flexture holder 600	Pan head screw with coned disk washer M4x20	1
	Tension flexture holder 6000	Pan head screw with coned disk washer M4x25	1
P	Yoke	Pan head screw with spring and plain washer M4x12	2
Q	Main mechanical frame	Allen head screw with spring and plain washer M6x20	2
R	Relay board	Pan head screw with spring and plain washer M3x6	1
S		Pan head screw with spring and plain washer M3x10	1
T	Position sensor board	Pan head screw with spring and plain washer M3x12	2
U	Bobbin	Pan head screw M3x4, brass, no-plating	2

[Blank page]

2.2 Lower Case

Exploded view

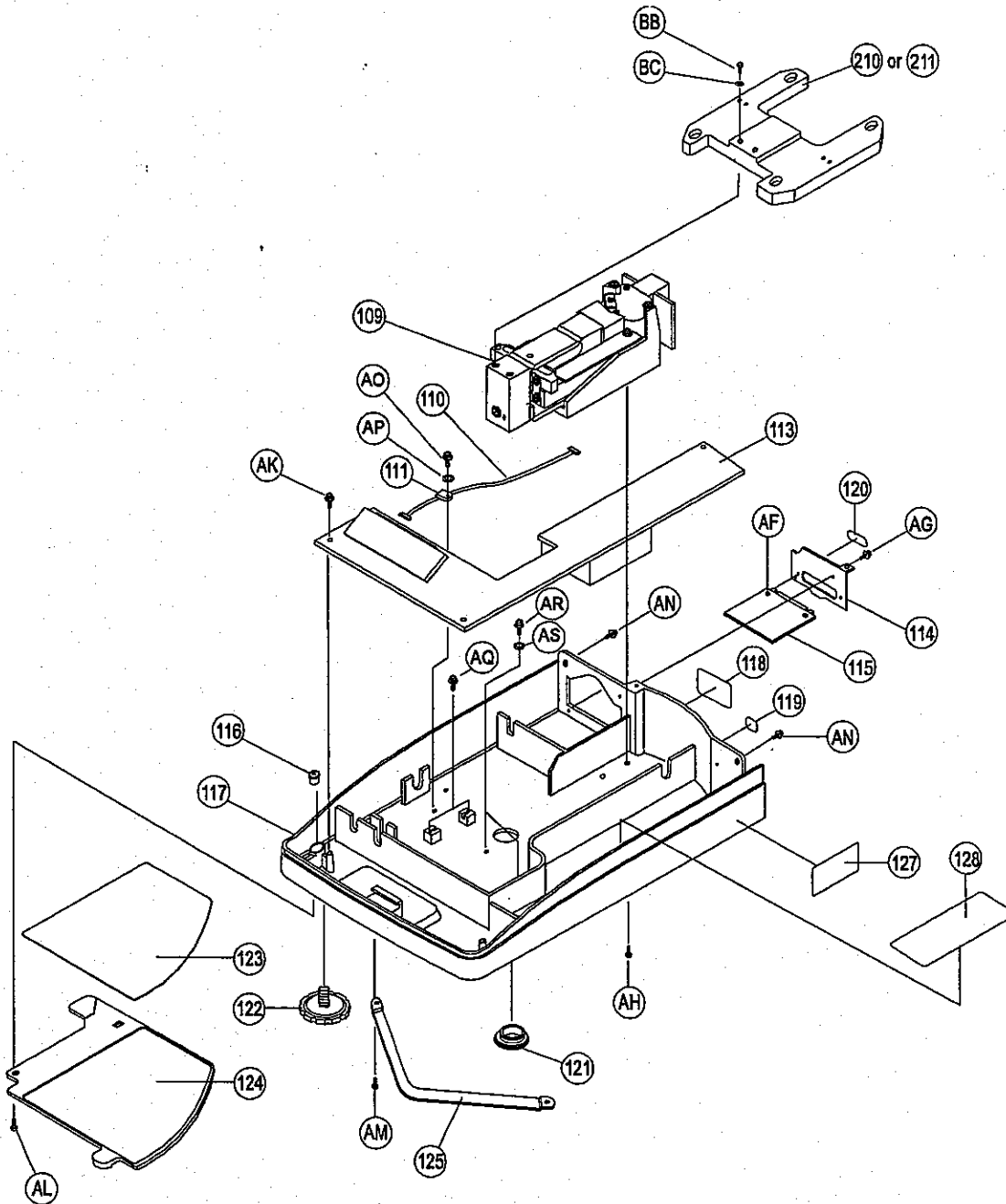

Model	GF series
Description	Lower Case Unit Exploded view 2
Stock No.	
Drawing No.	

Parts List

No.	Part Name	Part No.	Qty
109	Sensor unit		1
110	Serial interface cable	KO-1798	1
111	Cable clamper	10-NK-6N	1
113	Main board	7PZ-3470D/E/F	1
114	RS-232C panel	04-4007980	1
115	RS-232C board	7PZ-3471	1
116	Bubble spirit level	00-A46916	1
117	Lower case	03-1000119A	1
118	A&D CE label	08-4008169	1
119	Power label	08-4008151	1
120	RS-232C label	08-4008150	1
121	Under hook cover	07-A46858	1
122	leveling foot	06-4005645	2
123	English step sheet	08-4008863	1
124	Step card plate	07-3003685A	1
125	Step card guide	04-4007981	1
127	Serial label	08-4008904	1
128	Isolation sheet	07-C43674	1

No.	Position	Part Name	Qty
AF	RS-232C board	Pan head screw with spring and plain washer M3x8	2
AG	RS232C panel	Pan head screw with spring and plain washer M3x6	2
AH	Main mechanical frame	Allen head screw with toothed washer M4x10	4
AK	Main board	Pan head screw with spring and plain washer M3x6	3
AL	Step card	Flat head tapping screw M3x8	1
AM	Step card guide	Pan head screw M3x4	2
AN	Grounding terminal	Binding head with toothed washer M4x5	1
AO	Internal mass guide	Pan head screw with spring M4x5	2
AP		Flat washer M4	2
AQ	Seesaw part	Pan head screw with spring and plain washer M4x10	2
AR	Motor holder	an head screw with spring M4x5	2
AS		Flat washer M4	2

2.3 Upper Case

Exploded view

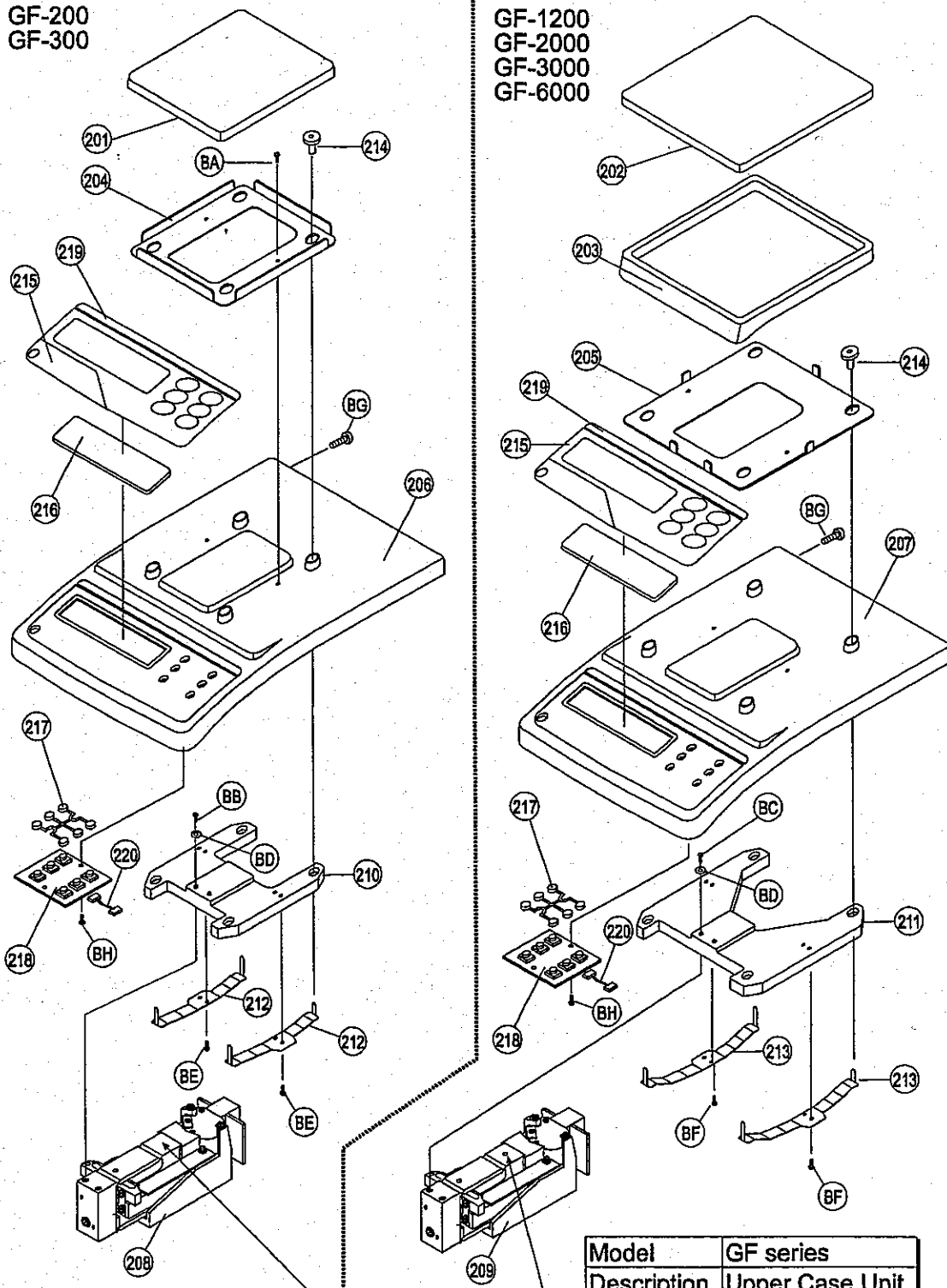

No marking with the roberval 600

The "O" marking with the roberval 8000.

Model	GF series
Description	Upper Case Unit Exploded view 3
Stock No.	
Drawing No.	

Installing the weighing pan unit

Screw in the pan support to secure.

Note: Install the pan support receptor so that the upper convex is to the inside. (: Figure with the convex part) For the right front position, use the one without the convex part. (: Figure without the convex part) New pan support receptors have a convex part. Remove it before using for the right front position. For the right front and the left rear, push the pan support receptor onto the shock absorber so that the top of the shock absorber protrudes from the pan support receptor. (In case of 600 systems, the spring of the shock absorber is weak. Therefore, hold the outer part of the pan support receptor and insert the pan support receptor while turning it to the right and to the left.)

Parts List

No.	Part Name	Part No.	Qty
201	Weighing pan 600	04-3003604	1
202	Weighing pan 6000	04-3003603	1
203	Breeze break frame 6000	03-2000465	1
204	Dust plate 600	04-3003608A	1
205	Dust plate 6000	04-2000470B	1
206	Upper case 600	03-1000118B	1
207	Upper case 6000	03-1000117B	1
208	Sensor unit for type 600		1
209	Sensor unit for type 6000		1
210	Pan support arm 600	03-2000467A	1
211	Pan support arm 6000	03-2000466A	1
212	S/A spring 600	04-3003606A	2
213	S/A spring 6000	04-3003605A	2
214	Pan support receptor	06-4007987B	4
215	Key sheet	08-3003976	1
216	Display filter	07-4007986	1
217	Key Caps	06-4008388	1
218	Switch board	7PZ-3474	1
219	Model label for GF-200	08-3003977A-1	1
	Model label for GF-300	08-3003977A-2	1
	Model label for GF-1200	08-3003977A-3	1
	Model label for GF-2000	08-3003977A-4	1
	Model label for GF-3000	08-3003977A-5	1
	Model label for GF-6000	08-3003977A-6	1
220	Switch board cable	KO-964-04W005	1

No.	Position	Part Name	Qty
BA	Dust plate	Binding head screw M4x5	2
BB	Pan support arm 600	Pan head screw M4x8	2
BC	Pan support arm 6000	Allen head screw M4x8	2
BD	Pan support arm	Coned disk spring	2
BE	S/A spring 600	Pan head screw with spring and plain washer M4x8	4
BF	S/A spring 6000	Allen head screw M4x8	4
BG	Upper case	Pan head screw with toothed washer M4x12	2
BH	Switch board	Pan head screw with spring and plain washer M3x6	2

[Blank page]

Circuit Diagram, PZ-3586 (Comparator)

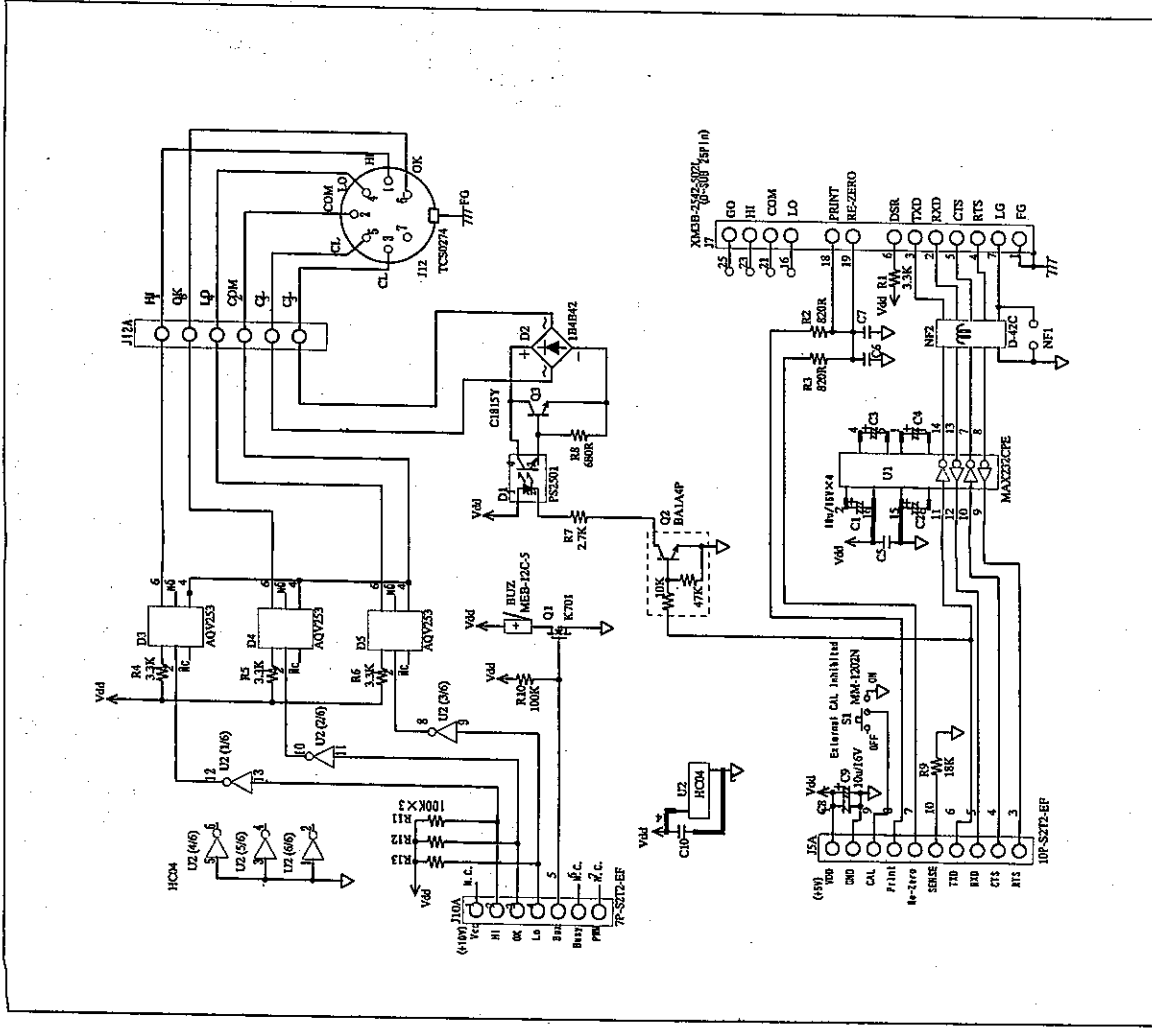

Model	GX/GF-04
Description	Comparator Output
Stock No.	PZ-3586
Drawing No.	QD-EC4-000222

Circuit Diagram, 7PZ-3601 (GX-06 Analog Output)

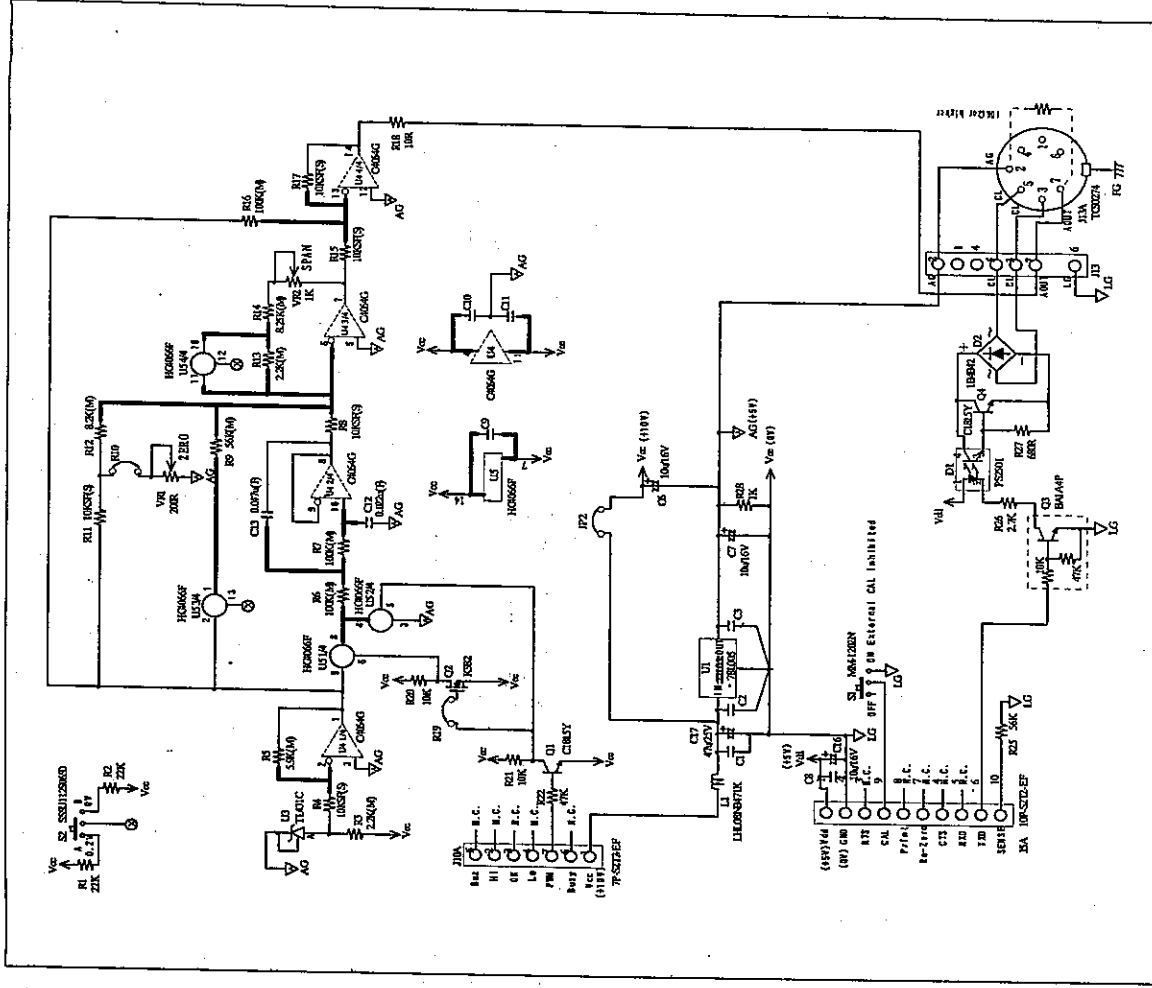

Model	GX/GF-06
Description	Analog Output
Stock No.	7PZ-3601
Drawing No.	QD-EC4-000225

Parts List of 7PZ-3470D/E/F

Symbols	Part No.	Part Name	Q'ty
	07-3003599	Display holder	1
	07-C43674	Isolation sheet	1
U1	UC-D78058-C41	CPU IC	1
C2, 3	CC-0.01U500V	Ceramic capacitor	2
C14	CC-0.022U	Ceramic capacitor	1
C23, 25	CC-220PT	Ceramic capacitor	2
C22	CC-330P	Ceramic capacitor	1
C29, 30, 31, 32, 41, 42, 43, 44	CC-330PT	Ceramic capacitor	8
C12, 13, 15	CC-0.1U25V-C	Ceramic capacitor	3
C1, 6, 7, 8, 9, 16, 17, 18, 33, 34, 36, 37, 46, 47, 48	CC-FK26Y5V104T	Ceramic capacitor	15
C10, 11, 24, 45	CK-ECA1CM101-T	Aluminum electrolytic capacitor 100 μ /16V	4
C26	CK-ECA1VM470-T	Aluminum electrolytic capacitor 47 μ /35V	1
C4, 5	CK-ECA1VM471-T	Aluminum electrolytic capacitor 470 μ /35V	2
D8	DI-1SS270T	Diode	1
D3	DI-F14AT	Diode	1
D2, 4	DI-SB10-03A2-T	Shottky diode	2
VFD	ED-CM1887G	VFD	1
J1	EJ-0470-01-230	Jack	1
F	FH-85PN0819	Fuse holder	2
	FS-218.800	Fuse	1
J5	JI-10P-S2L2-EF	IL-S pin	1
J4	JI-4P-ST2-EF	IL-S pin	1
J10	JI-7P-S2T2-EF	IL-S pin	1
J11	JI-9P-S2L2-EF	IL-S pin	1
	KO-1798	Cable for serial interface board	1
	KO-1800	Cable for relay board	1
	KO-964-04W005	Cable	1
L1, 2, 4	LL-LHL06TB470K	Inductor	3
L3	LL-LHL08TB471K	Inductor	1
AMZ51	MF-AMZ51	Analog module	1
Q1	QT-A1015YT	Transistor	1
R17,18, 23~28, 39, 46, 55~61, 68, 69	RC-NAT100KJT	Carbon resistor	19
R3	RC-NAT100RJT	Carbon resistor	1
R5, 47~53, 30	RC-NAT10KJT	Carbon resistor	9
R12	RC-NAT180RJT	Carbon resistor	1
R43	RC-NAT1MJT	Carbon resistor	1
R8, 54, 11, 70	RC-NAT1RJT	Carbon resistor	4
R40, 41, 42, 21, 22	RC-NAT22KJT	Carbon resistor	5
R4	RC-NAT33KJT	Carbon resistor	1
R19, 29, 45, 64, 38	RC-NAT4.7KJT	Carbon resistor	5
R44, 65, 66	RC-NAT470RJT	Carbon resistor	3

Symbols	Part No.	Part Name	Q'ty
R6, 7	RC-NAT47KJT	Carbon resistor	2
R67	RC-NAT680RJT	Carbon resistor	1
R9, 13	RM-RNM10KFT	Metal thin film resistor	2
R10	RM-RNM16.2KFT	Metal thin film resistor	1
R14	RM-RNM180KFT	Metal thin film resistor	1
U5	UA-S-8054ALR	Comparator	1
U3	UC-93LC66B/P	EEPROM	1
U7	UC-D16310GF	VFD driver IC	1
U6	UC-HC04	NOT	1
U2	UC-TC140G02AU12	Gate array IC	1
U11	UR-24M05HF	5V regulator	1
U10, 15	UR-7805AHF	5V regulator	2
U8, 9	UR-IR3M03A	DC/DC converter	2
X1	XT-C4SB12M-K02U	Ceramic resonator	1
	PC-3470C	Printed circuit Board	1

	R32	R33
7PZ-3470D	RL-MP84R00	RL-MP84R00
7PZ-3470E	RL-MP45R00	RL-MP45R00
7PZ-3470F	RL-MP10R00	-

Parts List of 7PZ-3471

Symbols	Part No.	Part Name	Q'ty
	04-4007980	RS232C panel	1
C505~508,	CC-FK26Y5V104T	Ceramic capacitor	4
C501~504,509	CK-SRA16VB-10T	Aluminum electrolytic capacitor 10 μ /16V	5
J7	JA-XM3B2542-502	D-sub connector, 25pin	1
J5A	JI-10P-S2T2-EF	IL-S pin	1
NF501	NF-ZBF253D-01	Ferrite beads	1
R501	RC-NAT3.3KJT	Carbon resistor	1
R502,503	RC-NAT820RJT	Carbon resistor	2
S501	SS-MM-1202N	Slide switch	1
U501	UC-MAX232CPE	RS-232C driver IC	1
	PC-3471C	Printed circuit board	1
	JA-XM4Z-0021	D-sub lock screw	2

Parts List of 7PZ-3472

Symbols	Part No.	Part Name	Q'ty
	03-4008391B	Position sensor holder	1
	07-4010682	Bush	1
C207	CC-0.01UT	Ceramic capacitor	1
C208	CC-10PT	Ceramic capacitor	1
C209	CC-68PT	Ceramic capacitor	1
C201~204	CC-FK26Y5V104T	Ceramic capacitor	4
C205, 206	CT-1V010T	Tantalum capacitor	2
D202	DI-MI-33H-2D	Diode pair	1
D201	DL-SLR-935A	Infrared rays diode	1
	KO-974-5-9	Cable for sensor board	1
Q201	QT-C1815YT	Transistor	1
R201, 206, 209	RC-NAT100KJT	Carbon resistor	3
R208	RC-NAT47KJT	Carbon resistor	1
R203,	RC-NAT680RJT	Carbon resistor	1
R205, 207	RF-180KSF	Metal thin film resistor	2
R204	RM-RNM240KFT	Metal thin film resistor	1
U201, 202	UA-C4062C	OP Amp.	2
	PC-3472C	Printed circuit board	1
R202	RC-NAT3.3KJT	Carbon resistor	1

Parts List of 7PZ-3474

Symbols	Part No.	Part Name	Q'ty
S401~406	SK-EVQ21307K	Push switch	6
C401, 402, 403	CC-330PT	Ceramic capacitor	3
R401, 402, 403	RC-NAT10KJT	Carbon resistor	3
R404, 405, 406	RC-NAT5.6KJT	Carbon resistor	3
J4A	JI-4P-S2L2-EF	IL-S pin	1
	PC-3474C	Printed circuit board	1

Parts List of 7PZ-3475

Symbols	Part No.	Part Name	Q'ty
C901	CC-FK26Y5V104T	Ceramic capacitor	1
J2	JI-05P-S2L2-EF	IL-S pin	1
J9	JI-2P-S2L2-EF	IL-S pin	1
J11A	JI-9P-S2L2-EF	IL-S pin	1
	PC-3475C	Printed circuit board	1

Parts List of 7PZ-3586 (GX/GF-04 Comparator Output)

Symbols	Part No.	Part Name	Q'ty
BZ1	ET-MEB-12C-5	Buzzer	1
C1-4,9	CK-SRA16VB-10	Chemical Capacitor	5
C5-8,10	CC-FK16Y5V1H104	Ceramic Capacitor	5
D1	DF-PS2501-1L/K	Photo coupler diode	1
D2	DI-1B4B42	Diode	1
D3,4,5	DF-AQV253	Photo Mos relay	3
J10A	JI-7P-S2T2-EF	IL-S Pin header	1
J12	JA-TCS0274	Din socket	1
J5A	JI-10P-S2T2-EF	IL-S Pin header	1
J7	JA-XM3B2542-502	25-pin Dsub Connector	1
J7	JA-XM4Z-0021	Lock screw	2
NF2	NF-D-42C	Noise filter	1
Q1	QF-K701	FET	1
Q2	QT-BA1A4P	Transistor	1
Q3	QT-C1815Y	Transistor	1
R1,4,5,6	RC-NAT3.3K	Carbon resistor	4
R10,11,12,13	RC-NAT100K	Carbon resistor	4
R2,3	RC-NAT820R	Carbon resistor	2
R7	RC-NAT2.7K	Carbon resistor	1
R8	RC-NAT680R	Carbon resistor	1
R9	RC-NAT18K	Carbon resistor	1
S1	SS-MM-1202N	Slide switch	1
U1	UC-MAX232CPE	RS-232C Driver	1
U2	UC-HC04	NOT	1
	PC-3586A	Printed circuit board	1
	04-4008870	Comparator panel	1
	08-4008885	OP-04 plate	1
	08-4008150	RS-232C plate	1
	KO-1879	Option board cable	1

Parts List of 7PZ-3601 (GX/GF-06 Analog Output)

Symbols	Part No.	Part Name	Qty
C1,2,3,8,9,10,11	CC-FK16K5V1H104	Ceramic capacitor	7
C12	CM-5002223J1	Film Capacitor	1
C13	CM-5002473J1	Film Capacitor	1
C17	CK-SRA25VB-47	Chemical Capacitor	1
C6,7,16	CK-SRA16VB-10	Chemical Capacitor	3
D1	DF-PS2501-1L-K	Photo coupler	1
D2	DI-1B4B42	Bridge diode	1
J10A	J1-7P-S2T2-EF	IL-S pin	1
J13A	JA-TCS0274	Din connector	1
J15A	J1-10P-S2T2-EF	IL-S pin	1
L1	LL-LHL08NB471K	Inductor	1
Q1,4	QT-C1815Y	Transistor	2
Q2	QF-K982	FET	1
Q3	QT-BA1A4P	Transistor	1
R1,2	RC-NAT22K	Carbon resistor	2
R14	RM-RNM8.25KF	Metal foiled resistor	1
R18	RC-NAT10R	Carbon resistor	1
R20,21	RC-NAT10K	Carbon resistor	2
R22	RC-NAT47K	Carbon resistor	1
R25	RC-NAT56K	Carbon resistor	1
R26	RC-NAT2.7K	Carbon resistor	1
R27	RC-NAT680R	Carbon resistor	1
R3,13	RM-RNM2.2KF	Metal foiled resistor	2
R4,8,11,15,17	RF-10KSF	Metal foiled resistor, flat	5
R5	RM-RNM5.9KF	Metal foiled resistor	1
R6,7,16	RM-RNM100KF	Metal foiled resistor	3
R9	RM-RNM56KF	Metal foiled resistor	1
S1	SS-MM1202N	Slide switch	1
S2	SS-SSSU112S06S0	Slide switch	1
U1	UR-TA78L005AP	Regulator	1
U3	UR-TL431CLPB	Regulator	1
U4	UA-C4064G	OP amp.	1
U5	UC-HC4066F	Analog switch	1
VR1	RV-V201	Volume	1
VR2	RV-V102	Volume	1
	04-4004017	OP-06 Panel	1
	08-4008976	OP-06 Plate	1
R28	RC-NAT1K	Carbon resistor	1
	PC-3601	Printed circuit board	1
	KO-1879	Option board cable	1

4. Parts Layout of Circuit Diagrams

Main Board: 7PZ-3470D, 7PZ-3470E, 7PZ-3470F

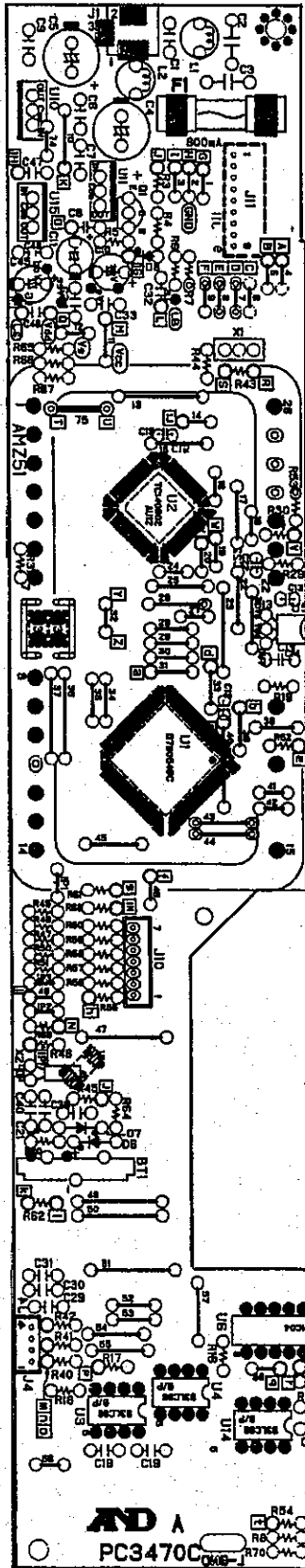

Type	Name	R32	R33	JP1	JP 2	JP 3
GF-200 GF-300	7PZ-3470D	84Ω	84 Ω	OPEN	Short	Open
GF-1200 GF-2000 GF-3000	7PZ-3470E	45 Ω	45 Ω	OPEN	Short	Open
GF-6000	7PZ-3470F	10 Ω	open	OPEN	Open	Short

Note: Following parts are not installed on the 7PZ-3770D/E/F

BT1	D6	R37
C19	D7	R74
C20	J6	U12
C21	Q2	U13
C27	R15	U14
C28	R16	U3
C38	R20	X2
C39	R34	Jumper 53
C40	R35	Jumper 72
D5	R36	Jumper 73

RS-232C Board: 7PZ-3471

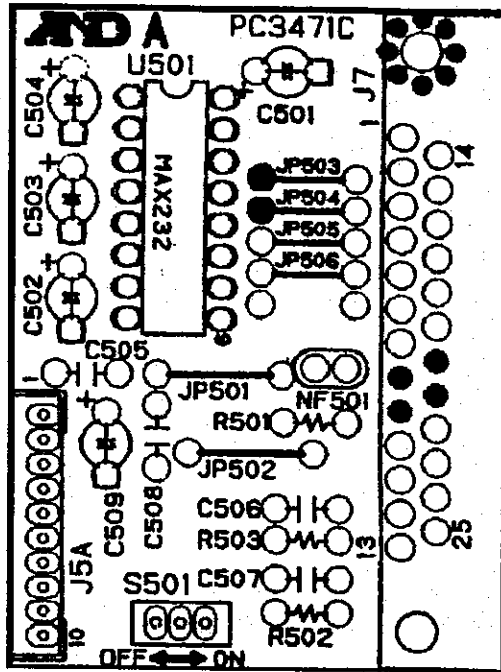

Position Sensor Board: 7PZ-3472

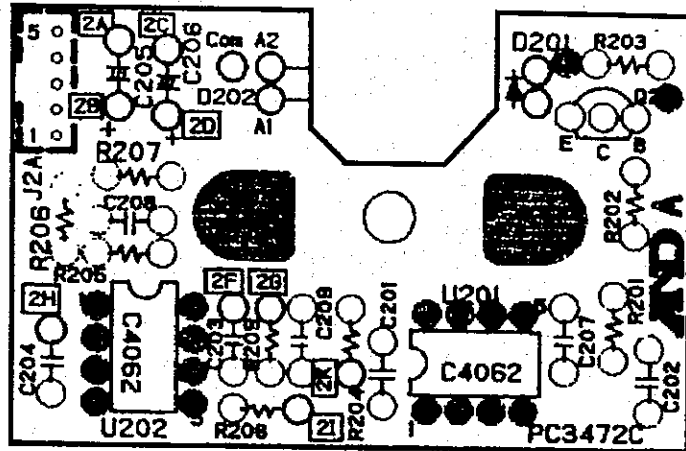

Switch Board: 7PZ-3474

* C404 is not installed on the board.

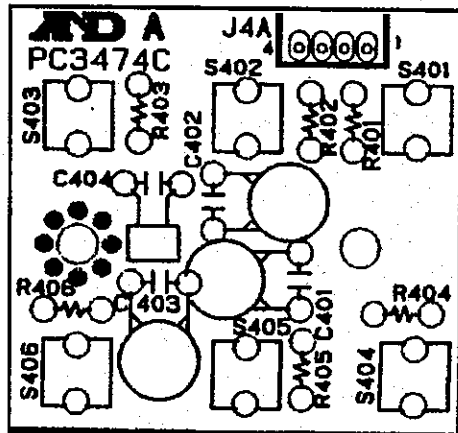

Relay Board: 7PZ-3475

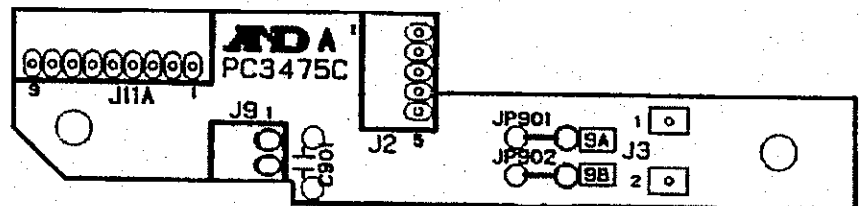

GX/GF-04 Comparator output: 7PZ-3586

* NF1 is not installed on the board.

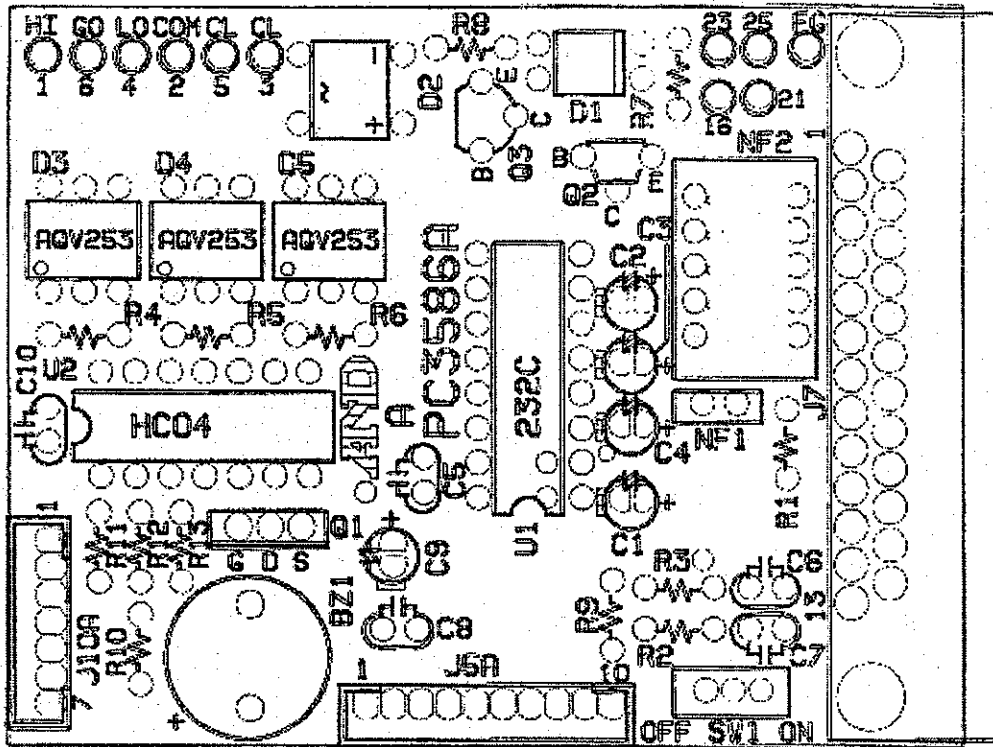

GX/GF-06 Analog output: 7 PZ-3601

* R23, R24, C4, C5, C14, C15, U2, JP1 are not installed on the board.

* R10 and R19 are jumpers.

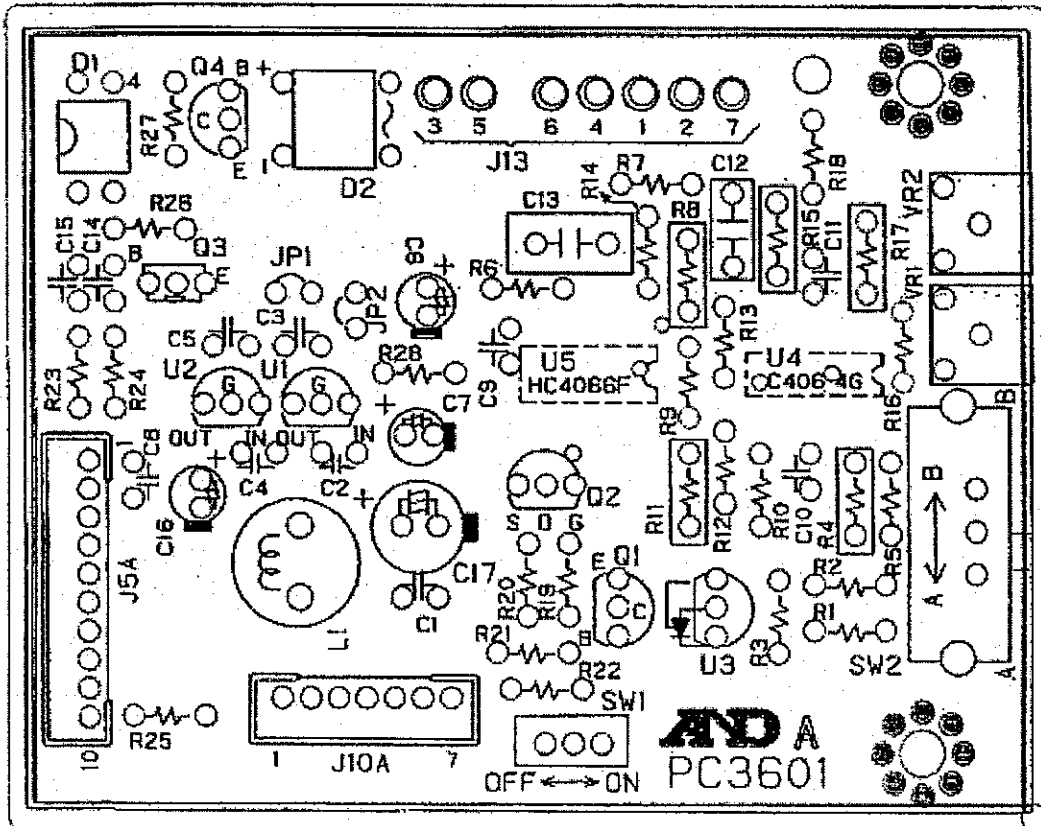

Appendix A

GX Technical Information

[Blank Page]

Contents

1.	Introduction	3
1.1	The Compositions of Products.....	3
1.2	Block Diagram of the Circuit	4
2.	Exploded Views and Parts List.....	7
2.1	Sensor Unit.....	7
2.1.1.	Parts List of Sensor Unit.....	8
2.2	Lower Case	11
2.2.1.	Parts List of Lower Case.....	12
2.3	Upper Case	15
2.3.1.	Parts List of Upper Case.....	16
3.	Circuit Diagram	18
3.1.1.	Parts List of 7PZ-3470 (A/B/C).....	20
3.1.2.	Parts List of 7PZ-3471	21
3.1.3.	Parts List of 7PZ-3472.....	22
3.1.4.	Parts List of 7PZ-3473	22
3.1.5.	Parts List of 7PZ-3474	22
3.1.6.	Parts List of 7PZ-3475	23
4.	Diagrams.....	24
4.1.1.	7PZ-3470A, 7PZ-3470B, 7PZ-3470C.....	24
4.1.2.	7PZ-3471 and 7PZ-3472	25
4.1.3.	7PZ-3473 and 7PZ-3474.....	25
4.1.4.	7PZ-3475	25

1. Introduction

1.1 The Compositions of Products

This manual describes each composition of the mechanical units, electronic units and software for the GX serieses. These serieses contain the same units or parts as the following table.

Model	Circuit board					
	Main board	RS-232C board	Position sensor board	Motor board	Switch board	Relay board
GX-200 GX-400 GX-600	7PZ-3470A	7PZ-3471	7PZ-3472	7PZ-3473	7PZ-3474	7PZ-3475
GX-2000 GX-4000 GX-6100	7PZ-3470B					
GX-6000 GX-8000	7PZ-3470C					

Model	Mechanical unit	Reference
GX-200 GX-400 GX-600	Sensor unit, Exploded view 1	These GX balances (GX200/400/600) are used the sensor unit of the roberval 600.
GX-2000 GX-4000 GX-6100 GX-6000 GX-8000	Lower case unit, Exploded view 2 Upper case unit, Exploded view 3	These GX balances (GX2000/4000/6100/6000/8000) are used the sensor unit of the roberval 6000.

Refer to each parts list concerning different units and parts.

Model	Software version	Reference
GX-200 GX-400 GX-600 GX-2000 GX-4000 GX-6100 GX-6000 GX-8000	Version 1.30 or updated one.	This software is common to all GX models.

1.2 Block Diagram of the Circuit

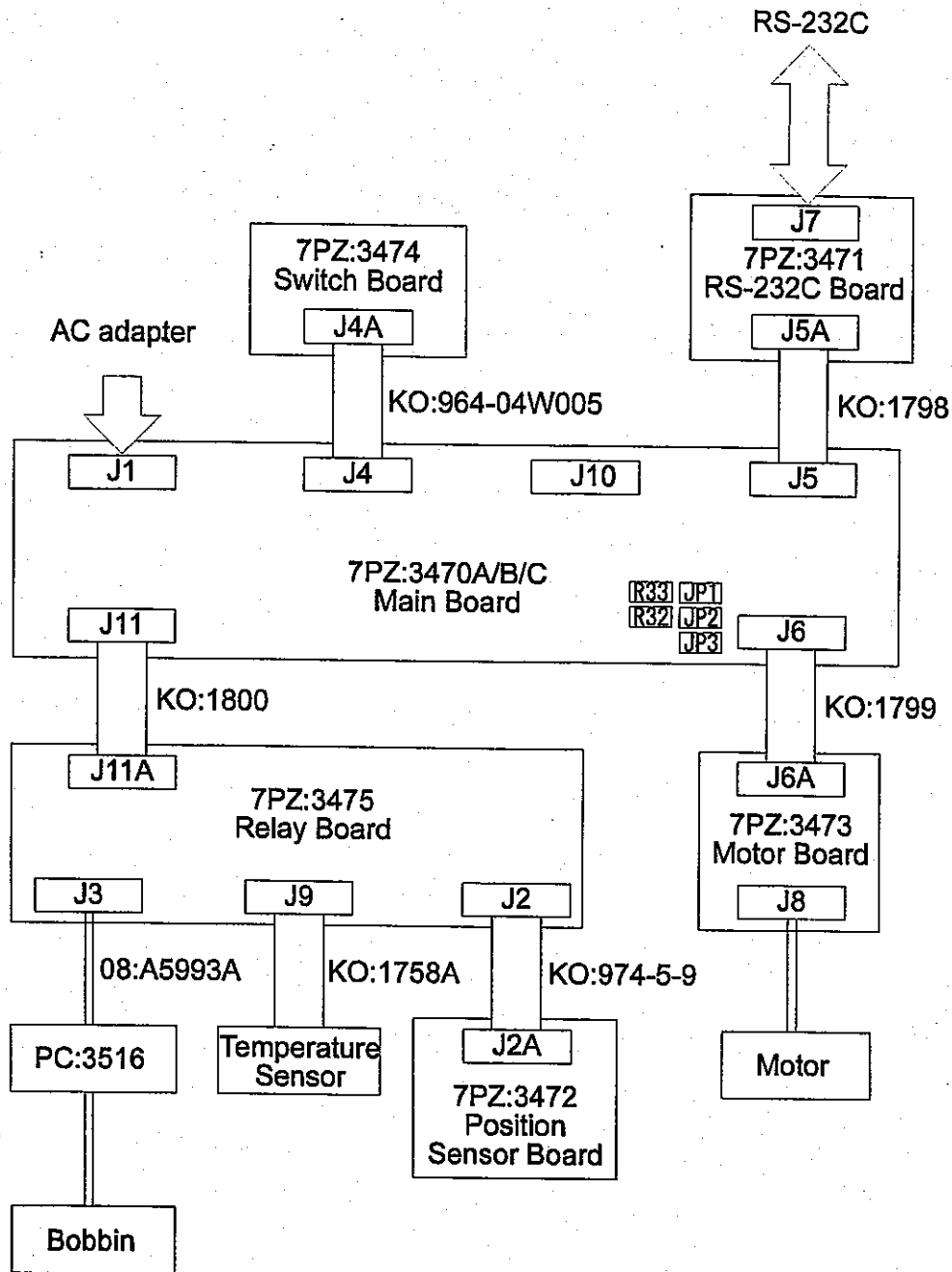

Deference of the main board (7PZ-3470A/B/C)

Type	Name	R32	R33	JP1	JP2	JP3
GX-200 GX-400 GX-600	7PZ-3470A	84Ω	84 Ω	Short	Short	Open
GX-2000 GX-4000 GX-6100	7PZ-3470B	45 Ω	45 Ω	Short	Short	Open
GX-6000 GX-8000	7PZ-3470C	10 Ω	—	Short	Open	Short

Cables

Cable No.	Name	Qty
KO-964-04W005	Switch board cable	1
KO-974-5-9	Position sensor cable	1
KO-1798	Serial interface cable	1
KO-1799	Motor board cable	1
KO-1800	Relay board cable	1
KO-1758A	Temperature sensor cable	1
08-A45993A	Wire	2
PC-3516	F.P.C. (GX)	1

[Blank Page]

2. Exploded Views and Parts List

2.1 Sensor Unit

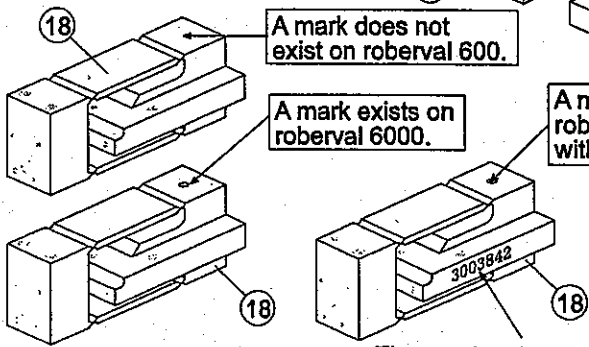
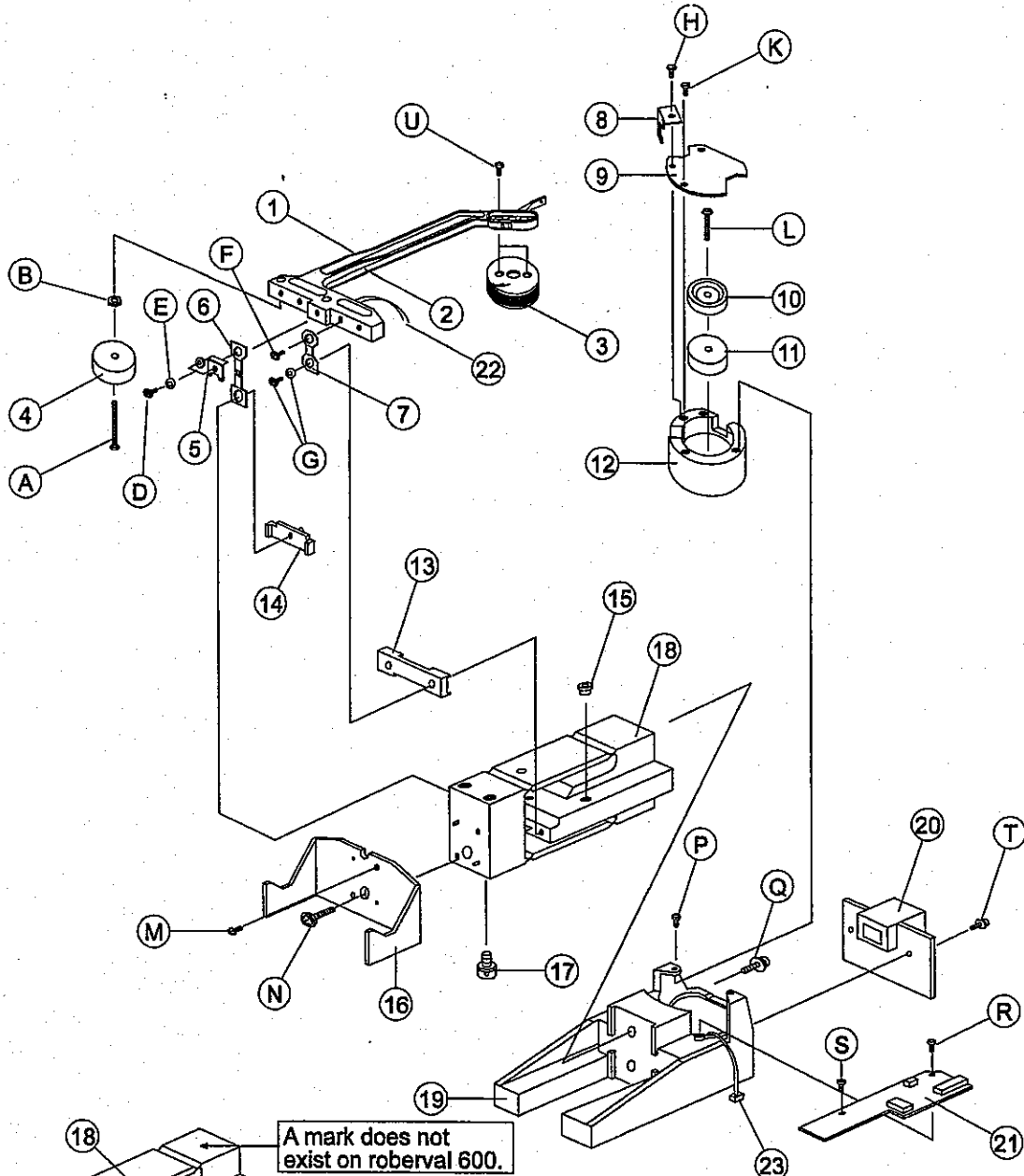

A mark does not exist on roberal 600.

A mark exists on roberal 6000.

A mark exists on roberal 8000 with cast.

The number (3003842) is marked on the roberal.

Model	GX series
Description	Sensor unit Exploded view 1
Stock No.	
Drawing No.	

2.1.1. Parts List of Sensor Unit

No.	Part Name	Part No.	Q'ty
1	Beam 600	03-3003595C	1
	Beam 6000	03-3003594C	1
2	Flexible print circuit	PC-3516	1
3	Bobbin	09-4008009	1
4	Trimming mass 600	05-4004892A	1
	Trimming mass 6000	05-4008821	1
5	Tension flexture holder ϕ 10.5	05-4008826	1
	Tension flexture holder1 square bracket	04-B47107A	1
6	Tension flexture for roberval 6000	04-4008310	1
7	Fulcrum flexture for roberval 6000	04-4008758	2
	Fulcrum flexture for roberval 600	04-4008313	2
8	Beam stopper	04-4007990	1
9	Shield plate	04-4007989	1
10	Pole piece	05-4007994	1
11	Magnet	00-4007995	1
12	Yoke	05-4007993	1
13	Attachment	03-4007970A	1
	Attachment 6000	03-4008768	1
14	Tension flexture holder 2	03-4007971A	1
15	Board spacer	05-4007992	1
16	Built-in internal mass hook	04-4007982	1
17	Under hook	05-B43355	1
18	Roberval 600	05-3003841	1
	Roberval 6000	05-3003840A	1
	Roberval (cast) 8000	03-3003842	1
19	Main mechanical frame	03-2000468A	1
20	Position sensor board	7PZ-3472	1
21	Relay board	7PZ-3475	1
22	Wire	08-4008510	2
23	Temp. sensor cable fixed to yoke	KO-1758A	1

No.	Position	Part Name	Q'ty
A	Trimming mass	Pan head screw M3x30	1
B		Nut M3	1
D	Tension flexture	Pan / truss head screw M4x8	1
E		Coned disk washer M4	1
F	Fulcrum flexture	Pan head screw with toothed washer M4x10	2
G		Pan head screw with distance ring and coned disk washer M4x10	2
H	Beam stopper	Pan head screw with spring and plain washer M3x6	1
K	Shield plate	Pan head screw with spring and plain washer M3x6	2
L	Magnet	Pan head screw with spring washer M4x16, brass, no-plating	1
M	Built-in calibration mass hook	Pan head screw with spring and plain washer M4x6	2
N	Tension flexture holder 600	Pan head screw with coned disk washer M4x20	1
	Tension flexture holder 6000	Pan head screw with coned disk washer M4x25	1
P	Yoke	Pan head screw with spring and plain washer M4x12	2
Q	Main mechanical frame	Allen head screw with spring and plain washer M6x20	2
R	Relay board	Pan head screw with spring and plain washer M3x6	1
S		Pan head screw with spring and plain washer M3x10	1
T	Position sensor board	Pan head screw with spring and plain washer M3x12	2
U	Bobbin	Pan head screw M3x4, brass, no-plating	2

[Blank Page]

2.2 Lower Case

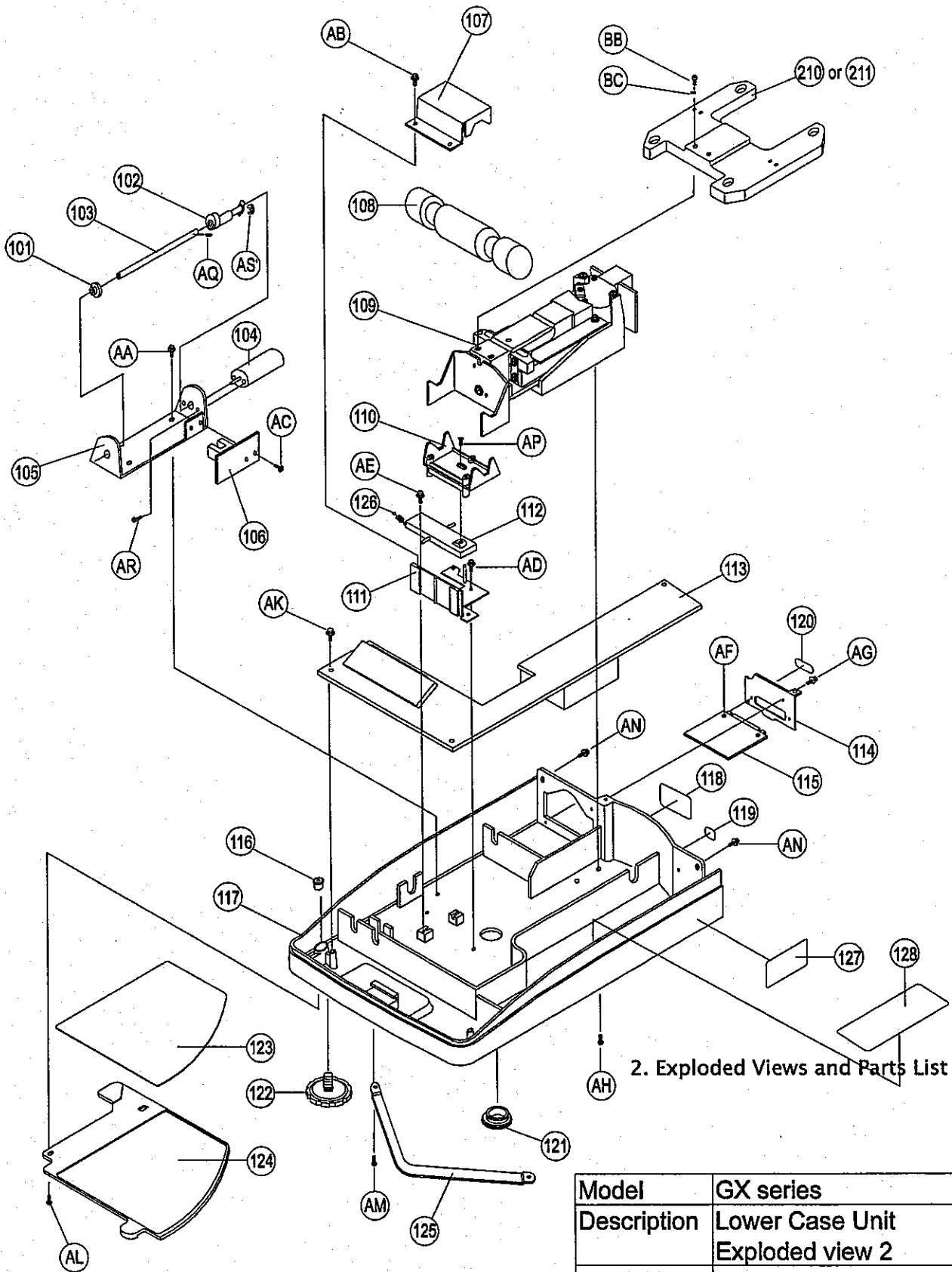

2. Exploded Views and Parts List

Model	GX series
Description	Lower Case Unit Exploded view 2
Stock No.	
Drawing No.	

2.2.1. Parts List of Lower Case

No.	Part Name	Part No.	Q'ty
101	Flange bush	10-80F-0503	1
102	Switching Cam	07-4007978A	1
103	Cam shaft	05-4007984A	1
104	Geared motor	10-4007979	1
105	Motor holder	04-3003600	1
106	Motor board	7PZ-3473	1
107	Internal mass limiter	04-4007983	1
108	500g Internal mass (built-in calibration mass)	05-4007985	1
109	Sensor unit		1
110	Internal mass guide	03-3003593	1
111	Internal mass frame	03-3003602A	1
112	Seesaw	03-4007969A	1
113	Main board	7PZ-3470A/B/C	1
114	RS-232C panel	04-4007980	1
115	RS-232C board	7PZ-3471	1
116	Bubble spirit level	00-A46916	1
117	Lower case	03-1000119A	1
118	A&D CE label	08-4008169	1
119	Power label	08-4008151	1
120	RS-232C label	08-4008150	1
121	Under hook cover	07-A46858	1
122	Leveling foot	06-4005645	2
123	English step sheet	08-4008415	1
	Japanese step sheet	08-4008389	1
124	Step card plate	07-3003685A	1
125	Step card guide	04-4007981	1
126	Seesaw spring	15-4008142	1
127	Serial label	08-4008315	1
128	Isolation sheet	07-C43674	1

No.	Position	Part Name	Q'ty
AA	Motor holder	Pan head screw with spring and plain washer M4x6	2
AB	Internal mass limiter	Pan head screw with spring and plain washer M4x6	2
AC	Motor board	Pan head screw with spring and plain washer M3x6	2
AD	Internal mass frame	Pan head screw with spring and plain washer M4x8	2
AE	Seesaw	Pan head screw with spring and plain washer M4x10	2
AF	RS-232C board	Pan head screw with spring and plain washer M3x8	2
AG	RS232C panel	Pan head screw with spring and plain washer M3x6	2
AH	Main mechanical frame	Allen head screw with toothed washer M4x10	4
AK	Main board	Pan head screw with spring and plain washer M3x6	3
AL	Step card	Flat head tapping screw M3x8	1
AM	Step card guide	Pan head screw M3x4	2
AN	Grounding terminal	Binding head with toothed washer M4x5	1
AP	Internal mass guide	Flat head M4x8, Plastic	1
AQ	Cam shaft	Continuous thread stud M3x3	1
AR	Geared motor	Binding head screw M2x5	1
AS	Cam	E ring, size 4	1

[Blank Page]

2.3 Upper Case

GX-200
GX-400
GX-600

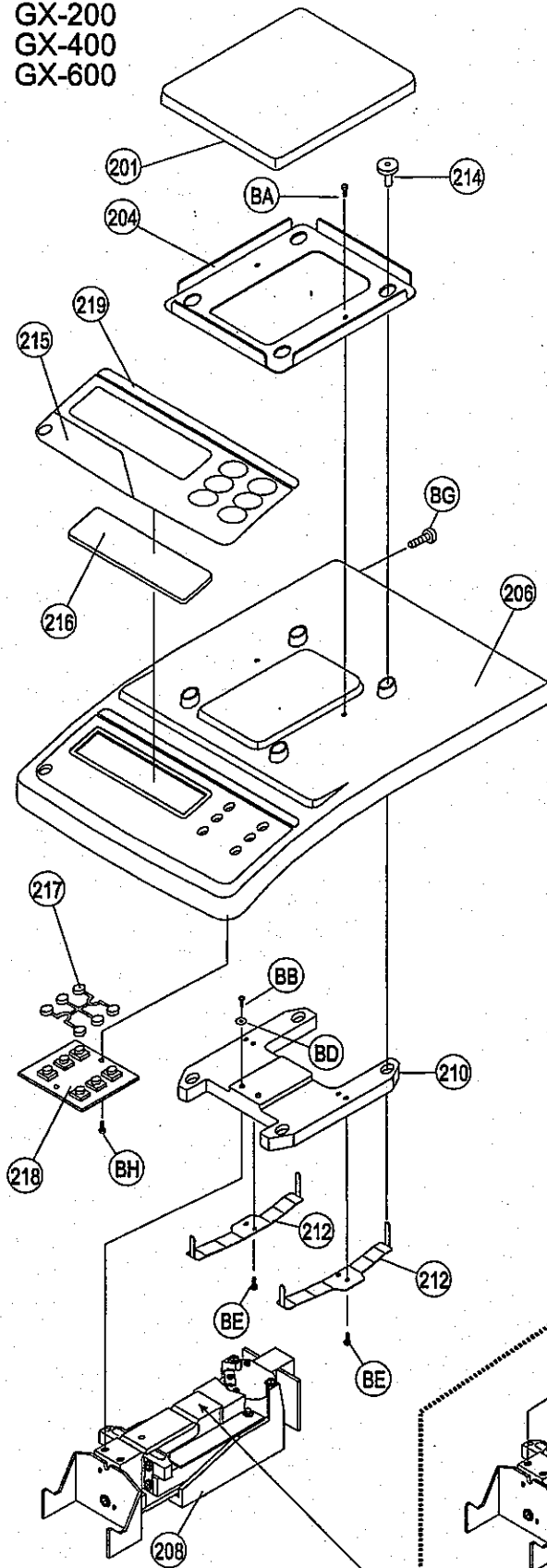

A mark does not exist on roberval 600.

GX-2000
GX-4000
GX-6100
GX-6000
GX-8000

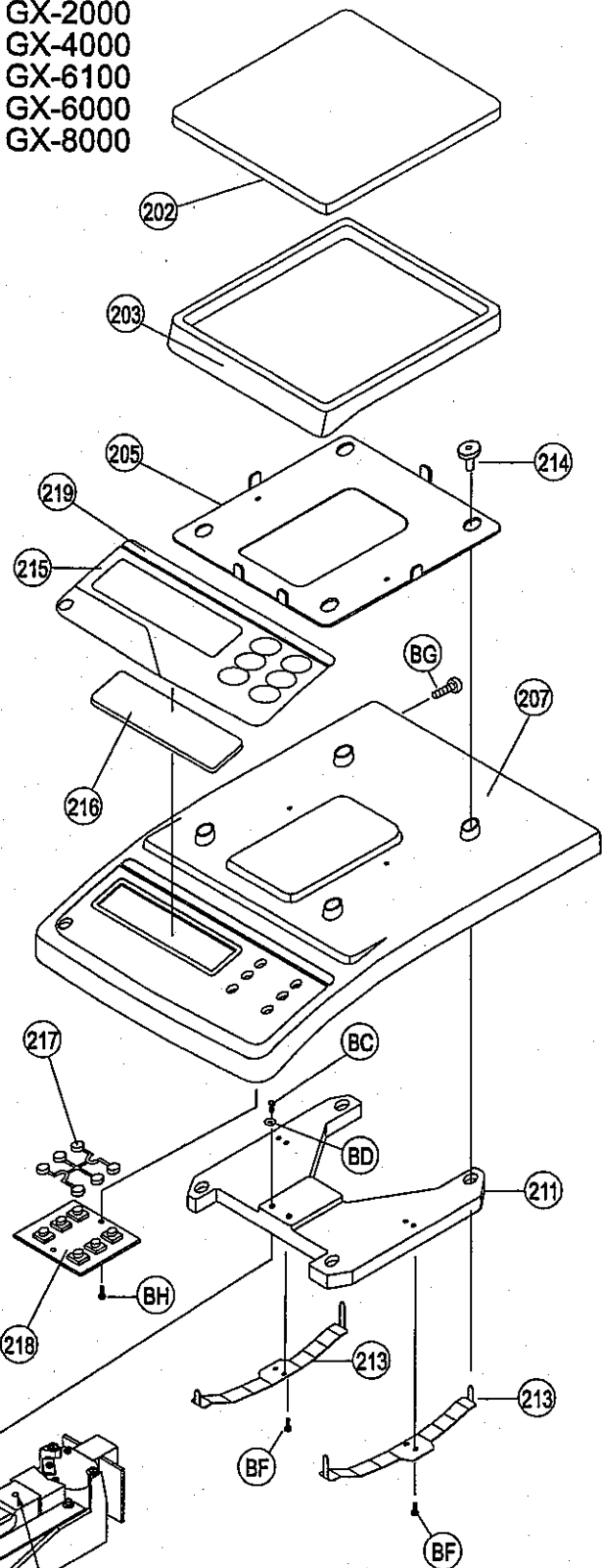

A mark exists on roberval 6000.

The GX6000/8000 are roberval with cast

Model	GX series
Description	Upper Case Unit Exploded view 3
Stock No.	
Drawing No.	

2.3.1. Parts List of Upper Case

No.	Part Name	Part No.	Q'ty
201	Weighing pan 600	04-3003604	1
202	Weighing pan 6000	04-3003603	1
203	Breeze break frame 6000	03-2000465	1
204	Dust plate 600	04-3003608A	1
205	Dust plate 6000	04-2000470B	1
206	Upper case 600	03-1000118B	1
207	Upper case 6000	03-1000117B	1
208	Sensor unit for type 600		1
209	Sensor unit for type 6000		1
210	Pan support arm 600	03-2000467A	1
211	Pan support arm 6000	03-2000466A	1
212	S/A spring 600	04-3003606A	2
213	S/A spring 6000	04-3003605A	2
214	Pan support receptor	06-4007987B	4
215	Key sheet	08-3003699A	1
216	Display filter	07-4007986	1
217	Key Caps	06-4008388	1
218	Switch board	7PZ-3474	1
219	Model label for GX-600	08-3003933-1	1
	Model label for GX-400	08-3003933-2	1
	Model label for GX-200	08-3003933-3	1
	Model label for GX-6100	08-3003933-4	1
	Model label for GX-4000	08-3003933-5	1
	Model label for GX-2000	08-3003933-6	1
	Model label for GX-6000	08-3003933-7	1
	Model label for GX-8000	08-3003933-8	1

No.	Position	Part Name	Q'ty
BA	Dust plate	Binding head screw M4x5	2
BB	Pan support arm 600	Pan head screw M4x8	2
BC	Pan support arm 6000	Allen head screw M4x8	2
BD	Pan support arm	Coned disk spring	2
BE	S/A spring 600	Pan head screw with spring and plain washer M4x8	4
BF	S/A spring 6000	Allen head screw M4x8	4
BG	Upper case	Pan head screw with toothed washer M4x12	2
BH	Switch board	Pan head screw with spring and plain washer M3x6	2

[Blank page]

3. Circuit Diagram

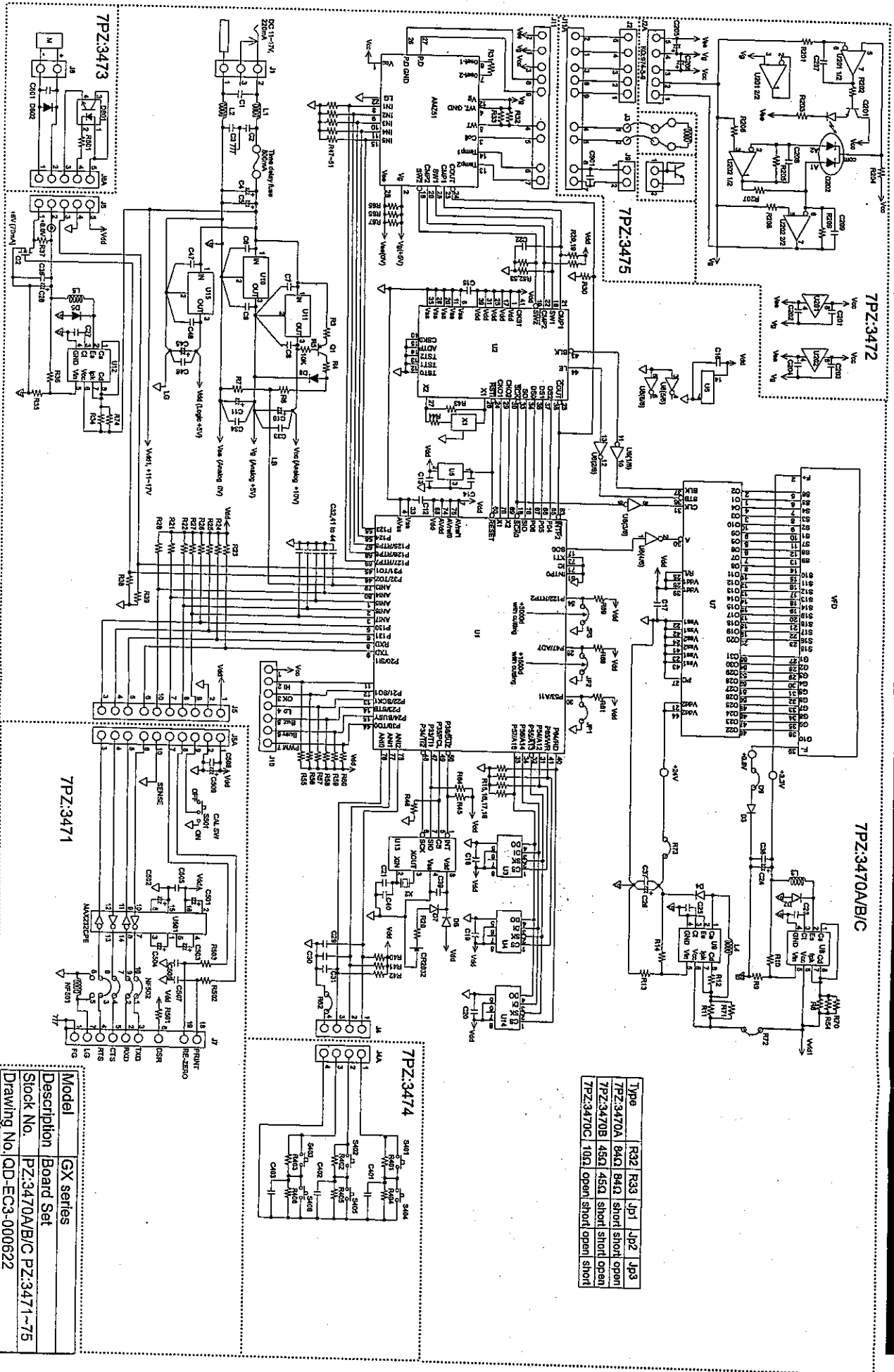

Type	R32	R33	U1	U2	U3
7PZ-3470A	84Ω	84Ω	short	short	open
7PZ-3470B	45Ω	45Ω	short	short	open
7PZ-3470C	10Ω	open	short	open	short

Model	GX series
Description	Board Set
Stock No.	PZ-3470A/B/C PZ-3471~75
Drawing No.	QD-EC3-000622

3.1.1. Parts List of 7PZ-3470 (A/B/C)

Symbols	Part No.	Part Name	Qty
	07-3003599	Display holder	1
	07-C 43674	Isolation sheet	1
U5	UC-D78058-C41	CPU IC	1
C2, 3	CC-0.01U500V	Ceramic capacitor	2
C14	CC-0.022U	Ceramic capacitor	1
C23, 25, 27	CC-220PT	Ceramic capacitor	3
C22	CC-330P	Ceramic capacitor	1
C29, 30, 31, 32, 41, 42, 43, 44	CC-330PT	Ceramic capacitor	8
C21	CC-4PT	Ceramic capacitor	1
C12, 13, 15	CC-0.1U25V-C	Ceramic capacitor (Chip)	3
C1, 6, 7, 8, 9, 16, 17, 18, 19, 20, 33, 34, 36, 37, 38, 39, 46, 47, 48	CC-FK26Y5V104T	Ceramic capacitor	19
C10, 11, 24, 28, 45	CK-ECA1CM101-T	Aluminum electrolytic capacitor 100 μ /16V	5
C26	CK-ECA1VM470-T	Aluminum electrolytic capacitor 47 μ /35V	1
C4, 5	CK-ECA1VM471-T	Aluminum electrolytic capacitor 470 μ /35V	2
D8	DI-1SS270T	Diode	1
D7	DI-1SS53T	Switching diode	1
D3	DI-F14AT	Diode	1
D6	DI-MA700AT	Shottky diode	1
D2, 4, 5	DI-SB10-03A2-T	Shottky diode	3
B	EB-CR2032-WT12	Lithium battery	1
VFD	ED-CM1887G	VFD	1
J1	EJ-0470-01-230	Jack	1
F	FH-85PN0819	Fuse holder	2
	FS-218.800	Fuse	1
J6	JI-05P-S2L2-EF	IL-S pin	1
J5	JI-10P-S2L2-EF	IL-S pin	1
J4	JI-4P-ST2-EF	IL-S pin	1
J10	JI-7P-S2T2-EF	IL-S pin	1
J11	JI-9P-S2L2-EF	IL-S pin	1
	KO-1798	Cable for serial interface board	1
	KO-1799	Cable for motor board	1
	KO-1800	Cable for relay board	1
	KO-964-04W005	Cable	1
L1, 2, 4	LL-LHL06TB470K	Inductor	3
L3, 5	LL-LHL08TB471K	Inductor	2
AMZ51	MF-AMZ51	Analog module	1
Q2	QF-K701	FET transistor	1
Q1	QT-A1015YT	Transistor	1
R15~18, 23~28, 37, 39, 46, 55~61, 68, 69	RC-NAT100KJT	Carbon resistor	22

Symbols	Part No.	Part Name	Q'ty
R3	RC-NAT100RJT	Carbon resistor	1
R5, 47~53, 30	RC-NAT10KJT	Carbon resistor	9
R12	RC-NAT180RJT	Carbon resistor	1
R43	RC-NAT1MJT	Carbon resistor	1
R8, 34, 54, 11, 70, 74	RC-NAT1RJT	Carbon resistor	6
R20	RC-NAT2.2KJT	Carbon resistor	1
R40, 41, 42, 21, 22	RC-NAT22KJT	Carbon resistor	5
R4	RC-NAT33KJT	Carbon resistor	1
R19, 29, 38, 45, 64	RC-NAT4.7KJT	Carbon resistor	5
R44, 65, 66	RC-NAT470RJT	Carbon resistor	3
R6, 7	RC-NAT47KJT	Carbon resistor	2
R67	RC-NAT680RJT	Carbon resistor	2
R9, 13	RM-RNM10KFT	Metal thin film resistor	2
R10	RM-RNM16.2KFT	Metal thin film resistor	1
R14	RM-RNM180KFT	Metal thin film resistor	1
R36	RM-RNM33KFT	Metal thin film resistor	1
R35	RM-RNM8.66KFT	Metal thin film resistor	1
U5	UA-S-8054ALR	Comparator	1
U3, 4, 14	UC-93LC66B/P	EEPROM	3
U7	UC-D16310GF	VFD driver IC	1
U6	UC-HC04	NOT	1
U13	UC-S-3511AEFS	Clock IC	1
U2	UC-TC140G02AU12	Gate array IC	1
U11	UR-24M05HF	5V regulator	1
U10, 15	UR-7805AHF	5V regulator	2
U8, 9, 12	UR-IR3M03A	DC/DC converter	3
X1	XT-C4SB12M-K02U	Ceramic resonator	1
X2	XT-DS-VT-200	Quartz Crystal unit	1
	PC-3470C	Printed circuit Board	1

	R32	R33	JP1	JP2	JP3
PZ-3470A	RL-MP84R00	RL-MP84R00	Short	Short	Open
PZ-3470B	RL-MP45R00	RL-MP45R00	Short	Short	Open
PZ-3470C	RL-MP10R00	-	Short	Open	Short

3.1.2. Parts List of 7PZ-3471

Symbols	Part No.	Part Name	Q'ty
	04-4007980	RS232C panel	1
C505~508,	CC-FK26Y5V104T	Ceramic capacitor	4
C501~504,509	CK-SRA16VB-10T	Aluminum electrolytic capacitor 10 μ /16V	5
J7	JA-XM3B2542-502	D-sub connector, 25pin	1
	JA-XM4Z-0021	Rock screw	2
J5A	JI-10P-S2T2-EF	IL-S pin	1
NF501	NF-ZBF253D-01	Ferrite beads	1
R501202	RC-NAT3.3KJT	Carbon resistor	2
R502503	RC-NAT820RJT	Carbon resistor	2
S501	SS-MM-1202N	Slide switch	1
U501	UC-MAX232CPE	RS-232C driver IC	1
	PC-3471C	Printed circuit board	1

3.1.3. Parts List of 7PZ-3472

Symbols	Part No.	Part Name	Q'ty
	03-4008391B	Position sensor holder	1
	07-4010682	Bush	1
C207	CC-0.01UT	Ceramic capacitor	1
C208	CC-10PT	Ceramic capacitor	1
C209	CC-68PT	Ceramic capacitor	1
C201~204	CC-FK26Y5V104T	Ceramic capacitor	4
C205, 206	CT-1V010T	Tantalum capacitor	2
D202	DI-MI-33H-2D	Diode pair	1
D201	DL-SLR-935A	Infrared rays diode	1
	KO-974-5-9	Cable for sensor board	1
Q201	QT-C1815YT	Transistor	1
R201, 206, 209	RC-NAT100KJT	Carbon resistor	3
R208	RC-NAT47KJT	Carbon resistor	1
R203,	RC-NAT680RJT	Carbon resistor	1
R205, 207	RF-180KSF	Metal thin film resistor	2
R204	RM-RNM240KFT	Metal thin film resistor	1
U201, 202	UA-C4062C	OP Amp.	2
	PC-3472C	Printed circuit board	1

3.1.4. Parts List of 7PZ-3473

Symbols	Part No.	Part Name	Q'ty
C601	CC-FK26Y5V104T	Ceramic capacitor	1
D601	DF-TLP864	Photo coupler	1
D602	DI-1SS270T	Diode	1
J6A	JI-05P-S2L2-EF	IL-S pin	1
R601	RC-NAT1.2KJT	Carbon resistor	1
	PC-3473C	Printed circuit board	1

3.1.5. Parts List of 7PZ-3474

Symbols	Part No.	Part Name	Q'ty
S401~406	SK-EVQ21307K	Push switch	6
C401, 402, 403	CC-330PT	Ceramic capacitor	3
R401, 402, 403	RC-NAT10KJT	Carbon resistor	3
R404, 405, 406	RC-NAT5.6KJT	Carbon resistor	3
J4A	JI-4P-S2L2-EF	IL-S pin	1
	PC-3474C	Printed circuit board	1

3.1.6. Parts List of 7PZ-3475

Symbols	Part No.	Part Name	Qty
C901	CC-FK26Y5V104T	Ceramic capacitor	1
J2	J1-05P-S2L2-EF	IL-S pin	1
J9	J1-2P-S2L2-EF	IL-S pin	1
J11A	J1-9P-S2L2-EF	IL-S pin	1
	PC-3475C	Printed circuit board	1

4. Diagrams

4.1.1. 7PZ-3470A, 7PZ-3470B, 7PZ-3470C

Main Board

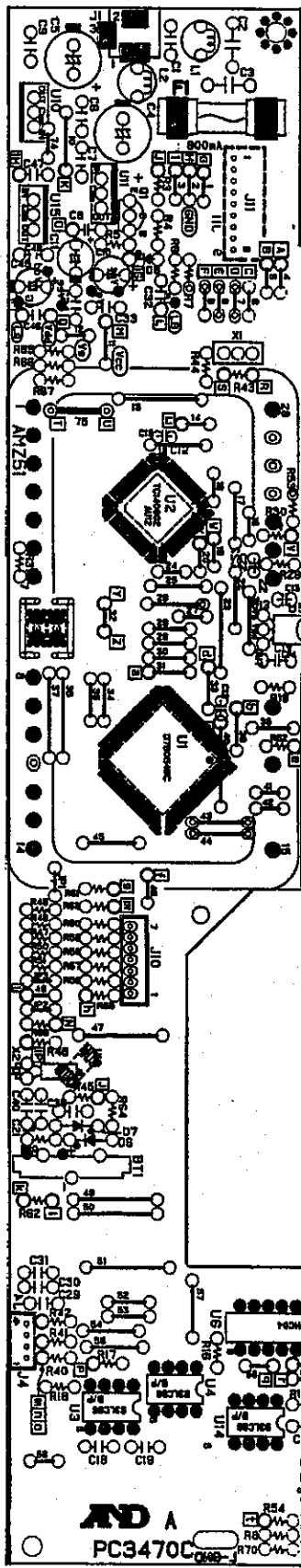

Type	Name	R32	R33	JP1	JP2	JP3
GX-200 GX-400 GX-600	7PZ-3470A	84Ω	84 Ω	Short	Short	Open
GX-2000 GX-4000 GX-6100	7PZ-3470B	45 Ω	45 Ω	Short	Short	Open
GX-6000 GX-8000	7PZ-3470C	10 Ω	open	Short	Open	Short

4.1.2. 7PZ-3471 and 7PZ-3472

7PZ-3471- RS-232C Board

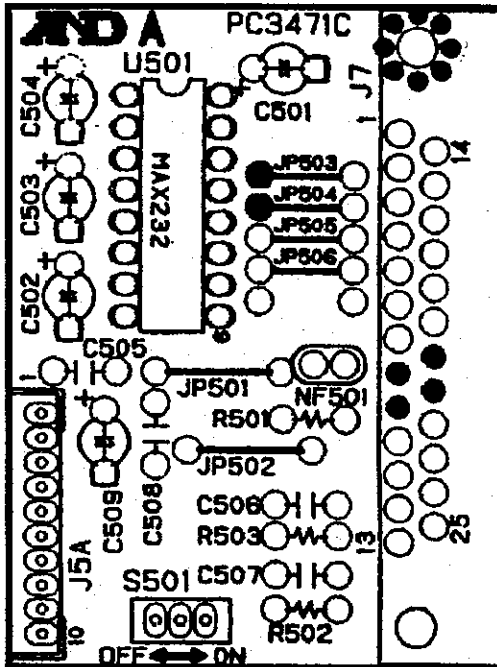

7PZ-3472- Position Sensor Board

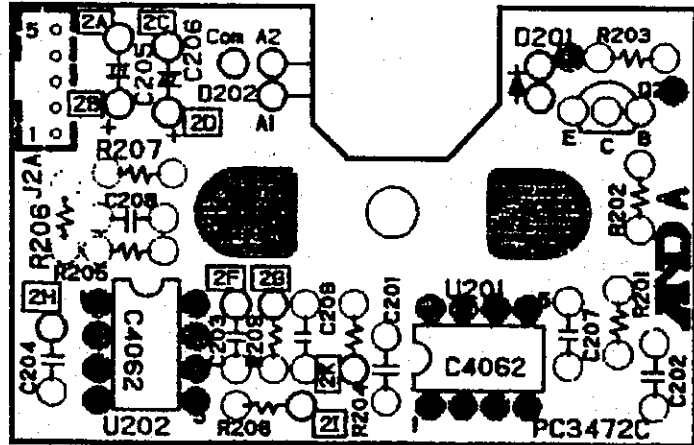

4.1.3. 7PZ-3473 and 7PZ-3474

7PZ-3473, Motor Board

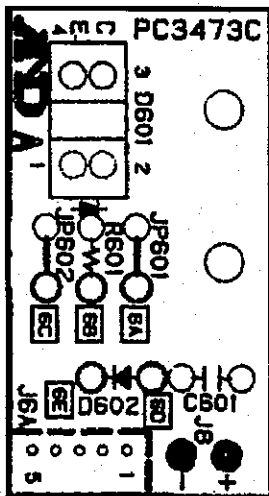

7PZ-3474, Switch Board

* C404 is not installed on the board.

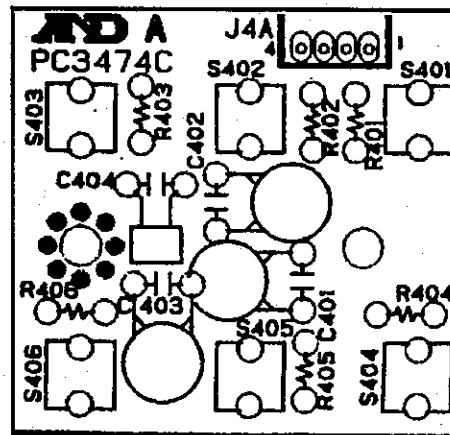

4.1.4. 7PZ-3475

Relay Board

